



Product Specification

AU OPTRONICS CORPORATION

(V) Preliminary Specifications

() Final Specifications

| | |
|------------|---|
| Module | 13.3" FHD Color TFT-LCD |
| Model Name | G133HAN01.0 |
| Note | LED backlight with driving circuit design |

| | | | |
|---|-------------|--|-------------------|
| Customer | Date | Approved by | Date |
| | | <u>Crystal Hsieh</u> | <u>2016/02/23</u> |
| Checked & Approved by | Date | Prepared by | Date |
| | | <u>Wennie Lee</u> | <u>2016/02/23</u> |
| Note: This Specification is subject to change without notice. | | GD BU Marketing Division AU Optronics Corporation | |



Product Specification

AU OPTRONICS CORPORATION

Contents

| | |
|---|-----------|
| 1. Handling Precautions..... | 4 |
| 2. General Description | 5 |
| 2.1 General Specification..... | 5 |
| 2.2 Optical Characteristics | 6 |
| 3. Functional Block Diagram..... | 10 |
| 4. Absolute Maximum Ratings..... | 11 |
| 4.1 Absolute Ratings of TFT LCD Module..... | 11 |
| 4.2 Absolute Ratings of Environment | 11 |
| 5. Electrical Characteristics | 12 |
| 5.1 TFT LCD Module..... | 12 |
| 5.2 Backlight Unit | 14 |
| 6. Signal Interface Characteristic | 15 |
| 6.1 Pixel Format Image | 15 |
| 6.2 The Input Data Format | 16 |
| 6.3 Signal Description (CN1)..... | 17 |
| 6.4 Interface Timing (LVDS)..... | 18 |
| 6.5 Power ON/OFF Sequence | 20 |
| 7. Connector & Pin Assignment | 21 |
| 7.1 TFT LCD Module..... | 21 |
| 7.2 Backlight Unit | 22 |
| 8. Panel Reliability Test | 24 |
| 9. Label and Package..... | 25 |
| 9.1 Shipping Label Format | 25 |
| 9.2 Carton Package | 25 |
| 10 .Mechanical Characteristics..... | 26 |
| 10.1 LCM Outline Dimension (Front View) | 26 |
| 10.2 LCM Outline Dimension (Rear View)..... | 27 |



Product Specification

AU OPTRONICS CORPORATION

1. Handling Precautions

- 1) Since front polarizer is easily damaged, please be cautious and not to scratch it.
- 2) Be sure to turn off power supply when inserting or disconnecting from input connector.
- 3) Wipe off water drop immediately. Long contact with water may cause discoloration or spots.
- 4) When the panel surface is soiled, wipe it with absorbent cotton or soft cloth.
- 5) Since the panel is made of glass, it may be broken or cracked if dropped or bumped on hard surface.
- 6) To avoid ESD (Electro Static Discharge) damage, be sure to ground yourself before handling TFT-LCD Module.
- 7) Do not open nor modify the module assembly.
- 8) Do not press the reflector sheet at the back of the module to any direction.
- 9) In case if a module has to be put back into the packing container slot after it was taken out from the container, do not press the center of the LED light bar edge. Instead, press at the far ends of the LED light bar edge softly. Otherwise the TFT Module may be damaged.
- 10) At the insertion or removal of the Signal Interface Connector, be sure not to rotate nor tilt the Interface Connector of the TFT Module.
- 11) TFT-LCD Module is not allowed to be twisted & bent even force is added on module in a very short time. Please design your display product well to avoid external force applying to module by end-user directly.
- 12) Small amount of materials without flammability grade are used in the TFT-LCD module. The TFT-LCD module should be supplied by power complied with requirements of Limited Power Source (IEC60950-1 or UL60950-1), or be applied exemption.
- 13) Severe temperature condition may result in different luminance, response time and lamp ignition voltage.
- 14) Continuous operating TFT-LCD display under low temperature environment may accelerate lamp exhaustion and reduce luminance dramatically.
- 15) The data on this specification sheet is applicable when LCD module is placed in landscape position.
- 16) Continuous displaying fixed pattern may induce image sticking. It's recommended to use screen saver or shuffle content periodically if fixed pattern is displayed on the screen.



2. General Description

G133HAN01.0 is a Color Active Matrix Liquid Crystal Display composed of a TFT LCD panel, a driver circuit, and LED backlight system. The screen format is intended to support the 16:9 FHD, 1920(H) x1080(V) screen and 16.7M colors (RGB 8-bits data driver) with LED backlight driving circuit.

G133HAN01.0 is designed for a display unit of industrial machine.

2.1 General Specification

The following items are characteristics summary on the table at 25 °C condition:

| Items | Unit | Specifications |
|----------------------------|----------------------|-----------------------------|
| Screen Diagonal | [inch] | 13.3" |
| Active Area | [mm] | 293.472 (H) x 165.078 (V) |
| Pixels H x V | | 1920 x 3(RGB) x 1080 |
| Pixel Pitch | [mm] | 0.15285x 0.15285 |
| Pixel Format | | R.G.B. Vertical Stripe |
| Display Mode | | AHVA |
| White Luminance (Center) | [cd/m ²] | 400 Typ. |
| Luminance Uniformity | | 80% (5 points, Typ.) |
| Contrast Ratio | | 700:1 (Typ.) |
| Response Time | [ms] | 25 (Typ.)/ 35 (Max.) |
| Nominal Input Voltage VDD | [Volt] | +3.3 (Typ.) |
| LCD Power Consumption | [Watt] | 1.8 W (Max. White Pattern) |
| LED Power Consumption | [Watt] | 15W (Max.) |
| Weight | [Grams] | TBD |
| Physical Size | [mm] | 309.7 x 184.1 x 9.6 (Typ.) |
| Electrical Interface | | LVDS |
| Surface Treatment | | Anti-glare |
| Support Color | | 16.7M Colors (RGB 8-bits) |
| Temperature Range | | |
| Operating | [°C] | 0 to +70 |
| Storage (Non-Operating) | [°C] | 0 to +70 |



Product Specification

AU OPTRONICS CORPORATION

2.2 Optical Characteristics

The optical characteristics are measured under stable conditions at 25°C (Room Temperature) :

| Item | Unit | Conditions | Min. | Typ. | Max. | Note | |
|---------------------------------|-------------------|--------------------------------------|----------|------|------|---------|---|
| Central Luminance | cd/m ² | | 320 | 400 | --- | 1, 3, 4 | |
| Viewing Angle | degree | Horizontal (Right) CR = 10 (Left) | 60 | 85 | --- | 3, 7 | |
| | | Vertical (Upper) CR = 10 (Lower) | 60 | 85 | --- | | |
| Luminance Uniformity | | 5 Points | 75 | 80 | --- | 1, 2, 3 | |
| Contrast Ratio | | | 500 | 700 | - | 3, 5 | |
| Response Time | msec | Rising + Falling | --- | 25 | 35 | 3, 6 | |
| Color / Chromaticity Coodinates | Red | Rx | CIE 1931 | TBD | TBD | TBD | 3 |
| | | Ry | | TBD | TBD | TBD | |
| | Green | Gx | | TBD | TBD | TBD | |
| | | Gy | | TBD | TBD | TBD | |
| | Blue | Bx | | TBD | TBD | TBD | |
| | | By | | TBD | TBD | TBD | |
| | White | Wx | | TBD | TBD | TBD | |
| | | Wy | | TBD | TBD | TBD | |
| NTSC | % | | - | 90 | - | | |

Note 1: 5 points position (Ref: Active area)

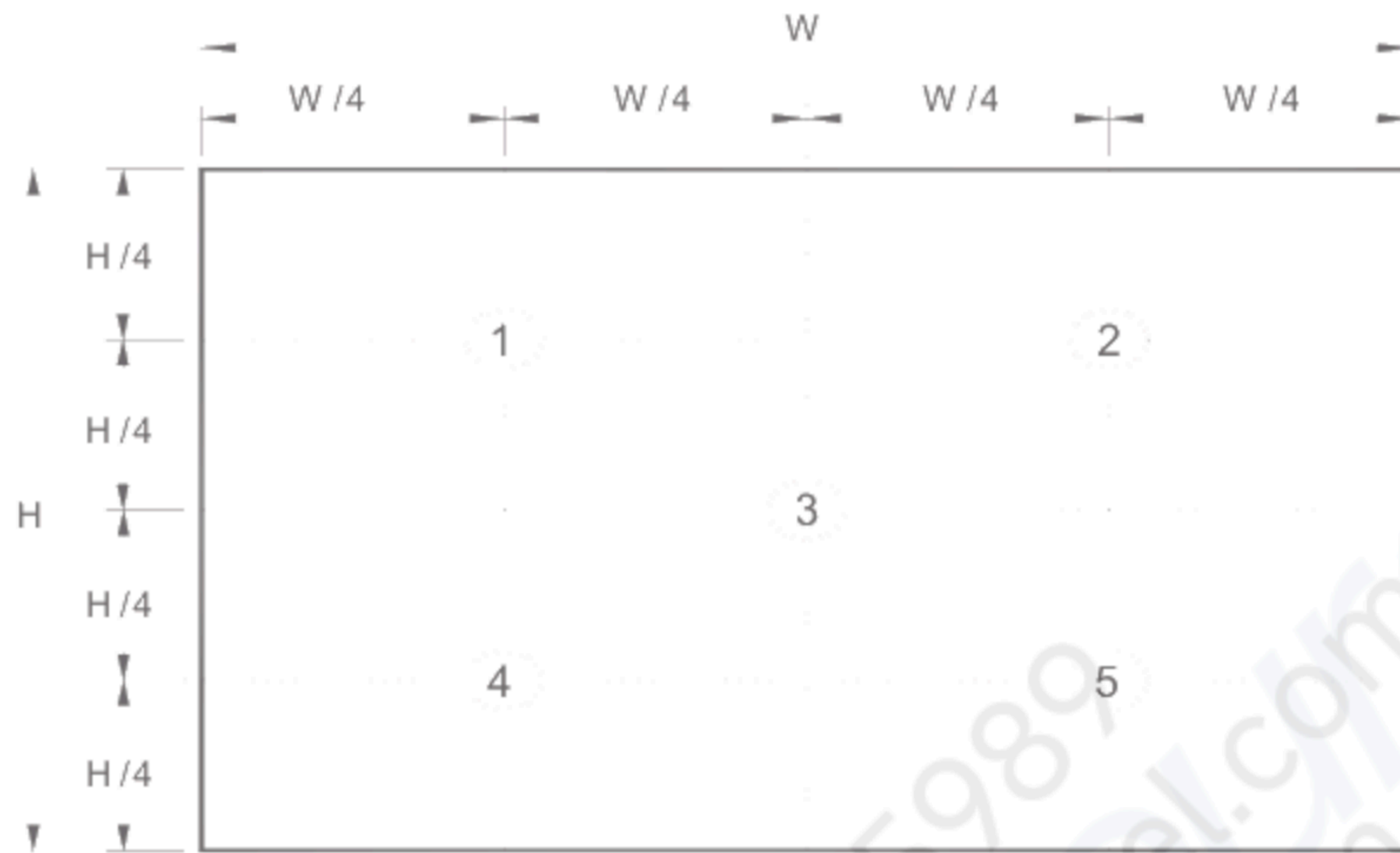

Note 2: The luminance uniformity of 5 points is defined by dividing the maximum luminance values by the minimum test point luminance

$$\delta_{w5} = \frac{\text{Maximum Brightness of five points}}{\text{Minimum Brightness of five points}}$$

Note 3: Measurement method

The LCD module should be stabilized at given temperature for 30 minutes to avoid abrupt temperature change during measuring. In order to stabilize the luminance, the measurement should be executed after lighting Backlight for 30 minutes in a stable, windless and dark room, and it should be measured in the center of screen.

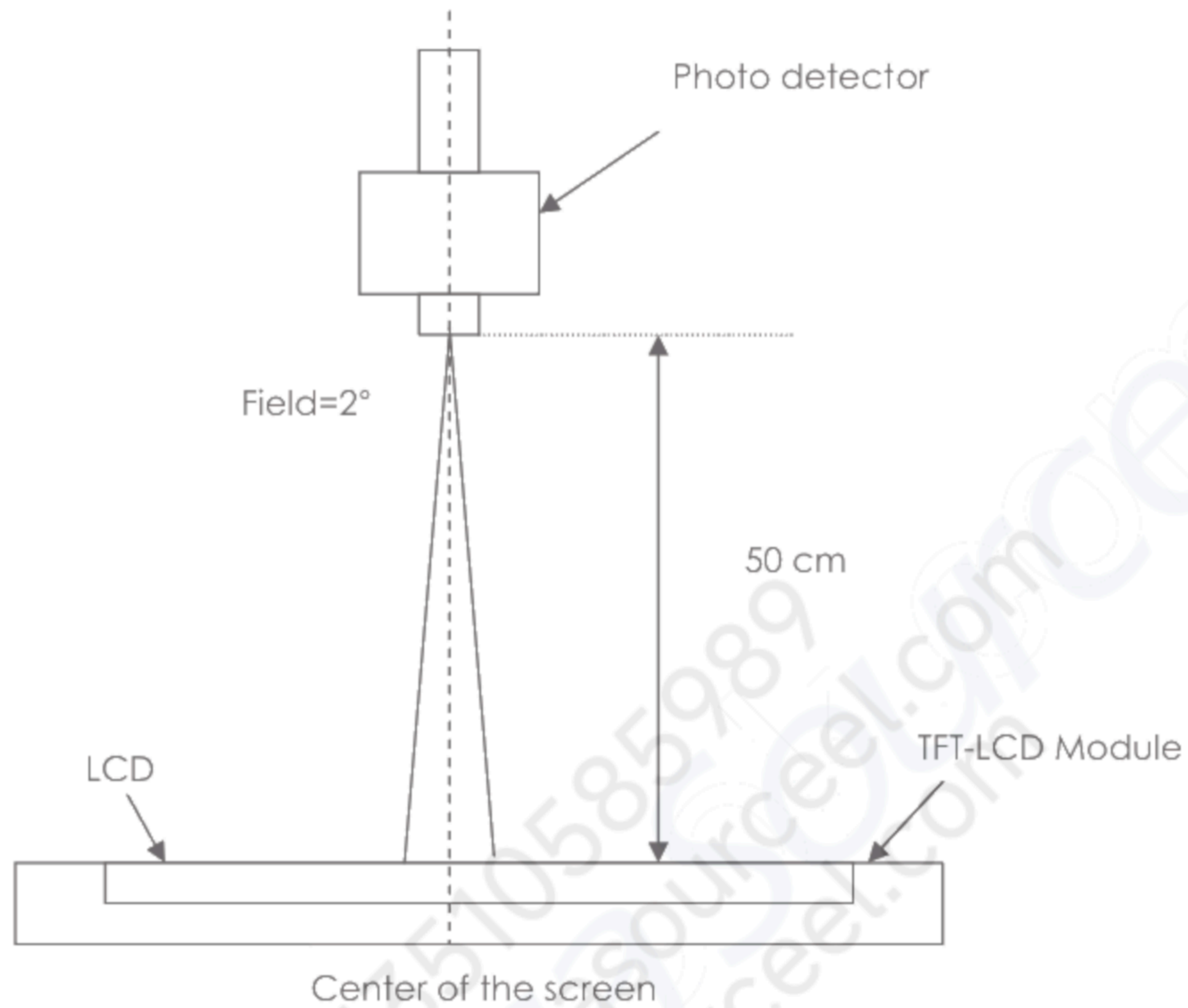

Note 4: Definition of Average Luminance of White (Y_L):

Measure the luminance of gray level 63 at 5 points, $Y_L = [L(1) + L(2) + L(3) + L(4) + L(5)] / 5$

L(x) is corresponding to the luminance of the point X at Figure in Note (1).

Note 5: Definition of contrast ratio:

Contrast ratio is calculated with the following formula.

$$\text{Contrast ratio (CR)} = \frac{\text{Brightness on the "White" state}}{\text{Brightness on the "Black" state}}$$

Note 6: Definition of response time:

The output signals of BM-7 or equivalent are measured when the input signals are changed from "Black" to "White" (falling time) and from "White" to "Black" (rising time), respectively. The response time interval is between the 10% and 90% of amplitudes. Refer to figure as below.

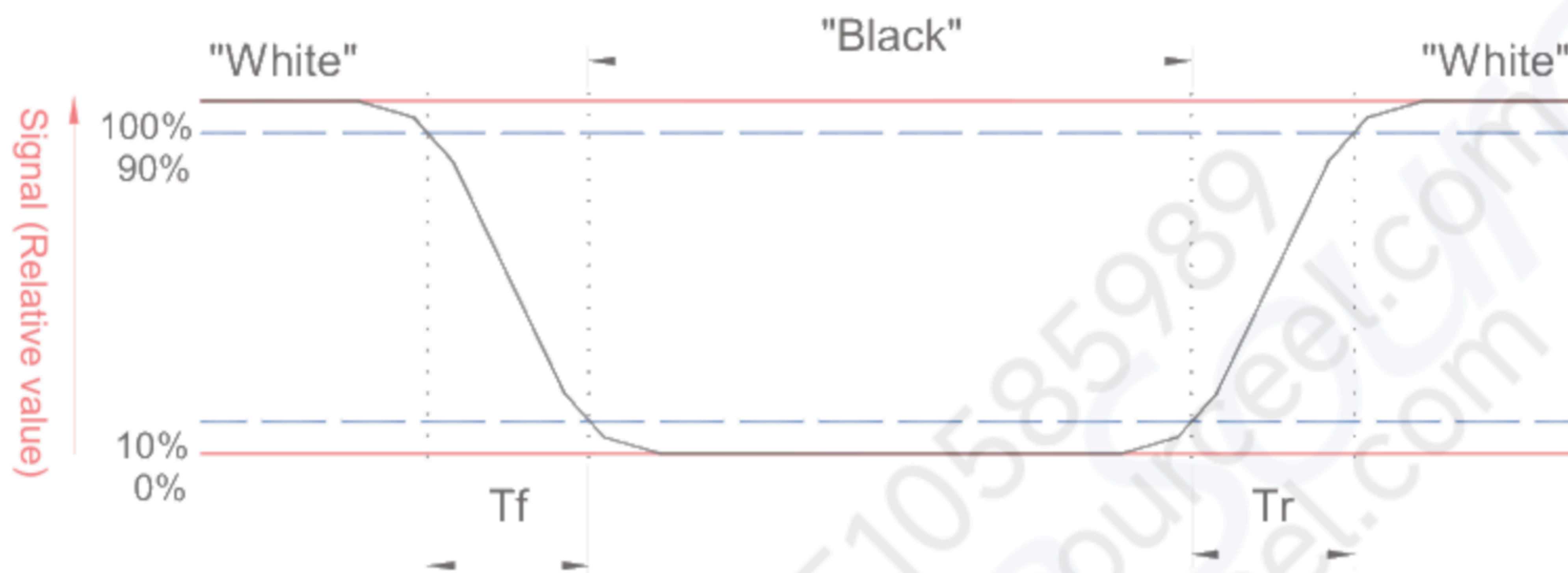

Note 7: Definition of viewing angle

Viewing angle is the measurement of contrast ratio >10, at the screen center, over a 180° horizontal and 180° vertical range (off-normal viewing angles). The 180° viewing angle range is broken down as follows; 90° (θ) horizontal left and right and 90° (ϕ) vertical, high (up) and low (down). The measurement direction is typically perpendicular to the display surface with the screen rotated about its center to develop the desired measurement viewing angle.

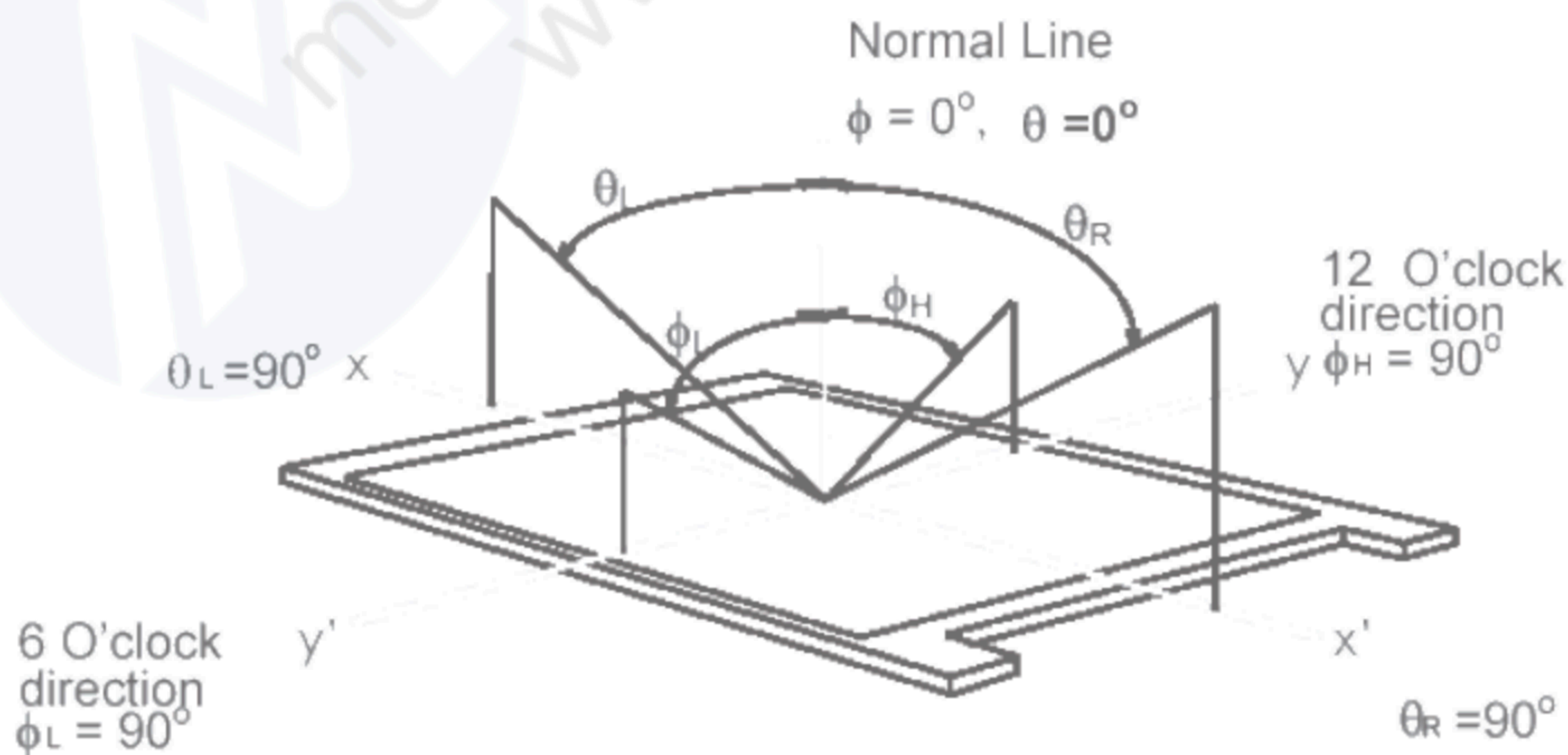

3. Functional Block Diagram

The following diagram shows the functional block of the 13.3 inch Color TFT-LCD Module:

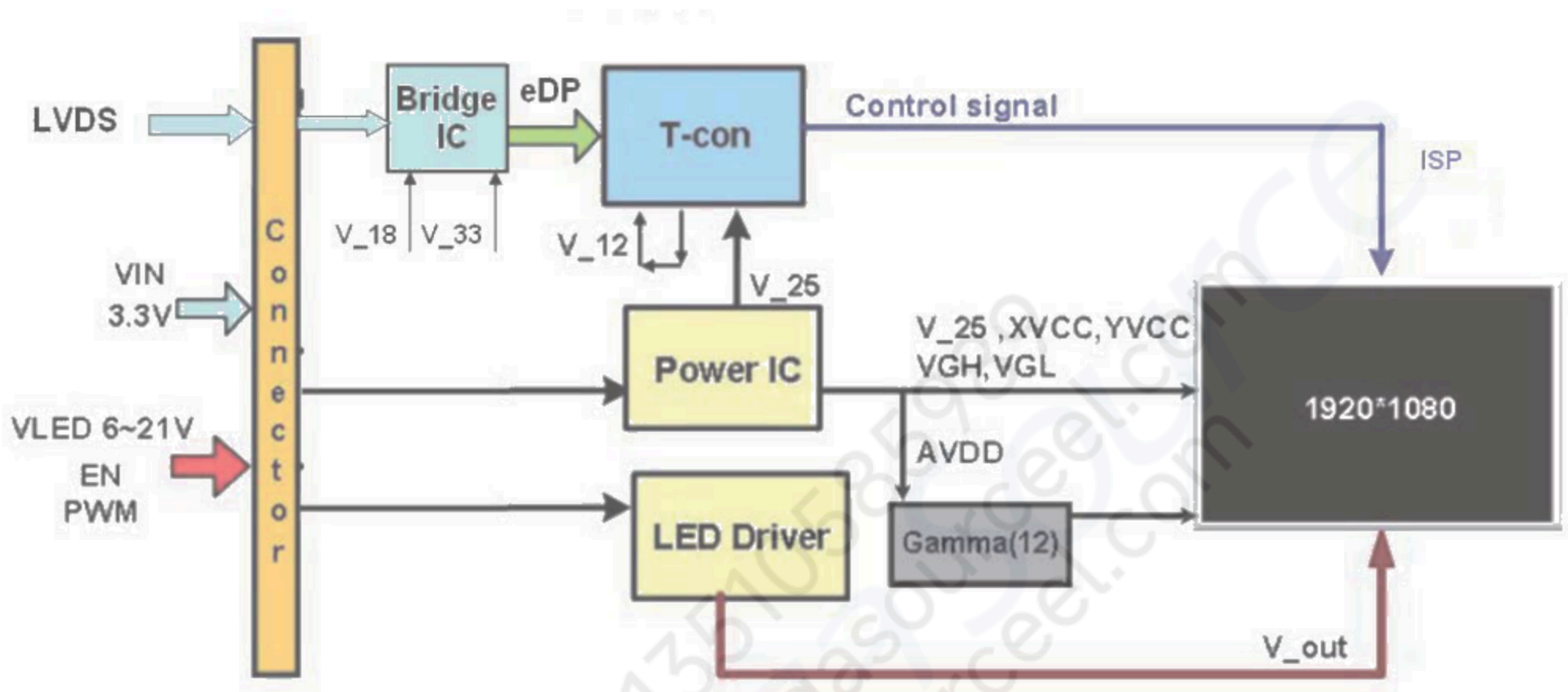



4. Absolute Maximum Ratings

An absolute maximum rating of the module is as following:

4.1 Absolute Ratings of TFT LCD Module

| Item | Symbol | Min | Max | Unit | Conditions |
|-------------------------|-------------------|------|---------|--------|-------------------|
| Logic/LCD Drive Voltage | VDD | -0.3 | +4.0 | [Volt] | Note 1,2 |
| BL Input Voltage | VLED | -0.3 | +34.0 | [Volt] | Note 1,2 |
| Signal Voltage | RinI-/+ , CkIN-/+ | -0.3 | VDD+0.3 | [Volt] | Note 1, I=0,1,2,3 |
| Signal Voltage | LED_EN , LED_PWM | -0.3 | +5.5 | [Volt] | Note 1,2 |

4.2 Absolute Ratings of Environment

| Item | Symbol | Min | Max | Unit | Conditions |
|---------------------|--------|-----|-----|-------|------------|
| Operating Temp. | TOP | 0 | +70 | [°C] | Note 4 |
| Operation Humidity | HOP | 8 | 90 | [%RH] | Note 4 |
| Storage Temperature | TST | 0 | +70 | [°C] | Note 4 |
| Storage Humidity | HST | 5 | 90 | [%RH] | Note 4 |

Note 1: At Ta (25°C)

Note 2: Permanent damage to the device may occur if exceed maximum values

Note 3: LED specification refer to section 5.2

Note 4: For quality performance, please refer to AUO IIS (Incoming Inspection Standard)

5. Electrical Characteristics

5.1 TFT LCD Module

5.1.1 Power Specification

Input power specifications are as follows;

The power specification are measured under 25°C and frame frequency under 60Hz

| Symble | Parameter | Min | Typ | Max | Units | Note |
|--------|--|-----|-----|-----|-------------|--------|
| VDD | Logic/LCD Drive Voltage | 3.0 | 3.3 | 3.6 | [Volt] | |
| PDD | VDD Power | - | - | 1.8 | [Watt] | Note 1 |
| IDD | IDD Current | - | - | 500 | [mA] | Note 1 |
| IRush | Inrush Current | - | - | 2 | [A] | Note 2 |
| VDDrp | Allowable Logic/LCD Drive Ripple Voltage | - | - | 200 | [mV] p-p | |

Note 1: Maximum Measurement Condition : White Pattern at 3.6V driving voltage ($P_{max}=V_{3.6V} \times I_{white}$)

Note 2: Measure Condition

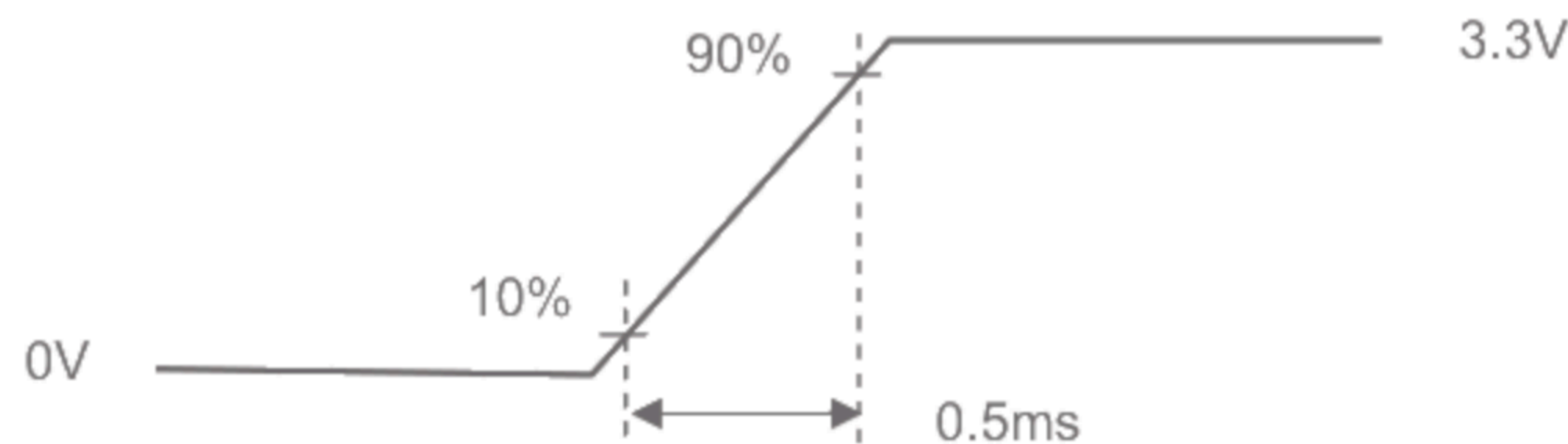
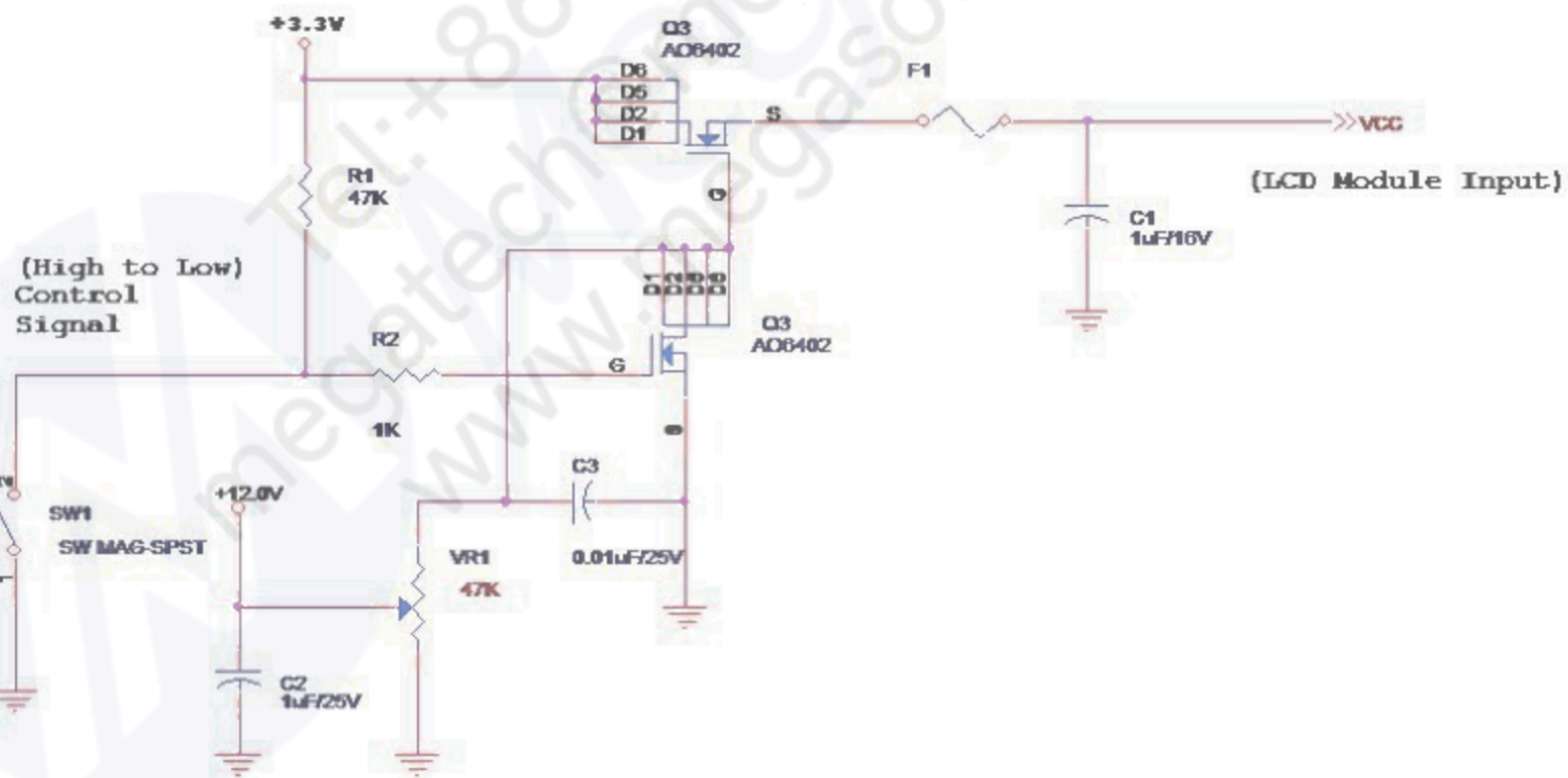

Vin rising time

5.1.2 Signal Electrical Characteristics

Input signals shall be low or High-impedance state when VDD is off.

Signal electrical characteristics are as follows;

| Symbol | Parameter | Min | Typ | Max | Units | Condition |
|------------|--|--------|-----|--------|--------|--|
| V_{TH} | Differential Input High Threshold | - | - | +100 | [mV] | $V_{CM} = 1.2V$ Note 1 |
| V_{TL} | Differential Input Low Threshold | -100 | - | - | [mV] | $V_{CM} = 1.2V$ Note 1 |
| $ V_{ID} $ | Input Differential Voltage | 100 | 400 | 600 | [mV] | Note 1 |
| V_{CM} | Differential Input Common Mode Voltage | +1.125 | - | +1.375 | [Volt] | $V_{TH} - V_{TL} = 200mV$ (max) Note 1 |

Note 1: LVDS Signal Waveform

Single-end Signal

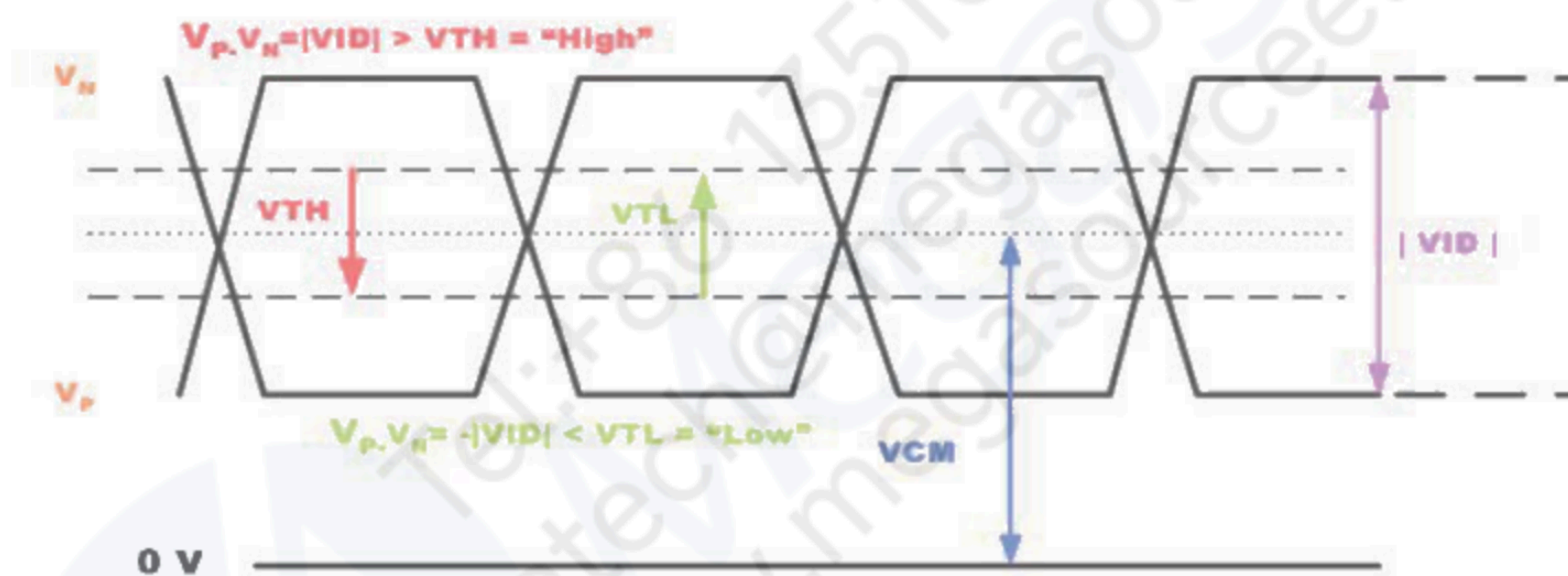

Differential Signal

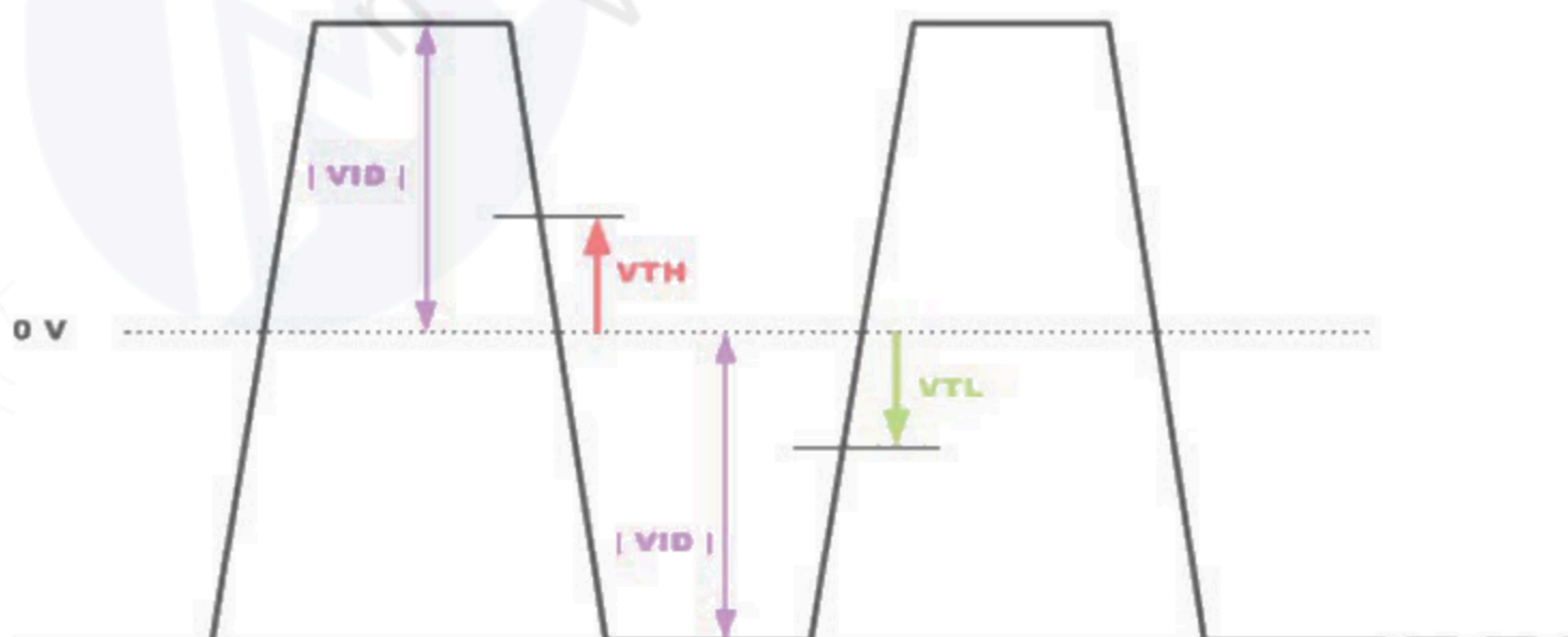

5.2 Backlight Unit

5.2.1 LED characteristics

| Parameter | Symbol | Min | Typ | Max | Units | Condition |
|-----------------------------|--------|-----|--------|-----|--------|---------------------|
| Backlight Power Consumption | PLED | - | - | 15W | [Watt] | (Ta=25□), Note 1 |
| LED Life-Time | N/A | - | 50,000 | - | Hour | (Ta=25□), Note 2 |

Note 1: Calculator value for reference $P_{LED} = V_F$ (Normal Distribution) * I_F (Normal Distribution) / Efficiency

Note 2: The LED life-time define as the estimated time to 50% degradation of initial luminous.

5.2.2 Backlight input signal characteristics

| Parameter | Symbol | Min | Typ | Max | Units | Remark |
|-----------------------------|----------------------|------|------|------|--------|--|
| LED Power Supply | VLED | 10.8 | 12.0 | 13.2 | [Volt] | Define as Connector Interface (Ta=25°C) |
| LED Input current | ILED | - | 1.25 | - | [A] | |
| LED Enable Input High Level | LED_EN | 2 | - | 5 | [Volt] | |
| LED Enable Input Low Level | | - | - | 0.8 | [Volt] | |
| PWM Logic Input High Level | LED_PWM | 2 | - | 5 | [Volt] | |
| PWM Logic Input Low Level | | - | - | 0.52 | [Volt] | |
| PWM Input Frequency | FPWM | 200 | - | 10K | Hz | |
| PWM Duty Ratio | Duty | 5 | - | 100 | % | |
| LED Inrush Current | ILED _{Rush} | - | - | 3 | [A] | |

6.2 The Input Data Format

| Interface | Type | Data |
|-----------|-------|-------|
| LVDS | JEIDA | 8 bit |

JEIDA / NS Mapping Format (Using JEIDA)

| | | | | | | | |
|-------------|----------|----------|----------|----------|----------|----------|----------|
| RXIN1D0 N/P | J:RA6=G2 | J:RA5=R7 | J:RA4=R6 | J:RA3=R5 | J:RA2=R4 | J:RA1=R3 | J:RA0=R2 |
| RXIN2D0 N/P | N:RA6=G0 | N:RA5=R5 | N:RA4=R4 | N:RA3=R3 | N:RA2=R2 | N:RA1=R1 | N:RA0=R0 |
| RXIN1D1 N/P | J:RB6=B3 | J:RB5=B2 | J:RB4=G7 | J:RB3=G6 | J:RB2=G5 | J:RB1=G4 | J:RB0=G3 |
| RXIN2D1 N/P | N:RB6=B1 | N:RB5=B0 | N:RB4=G5 | N:RB3=G4 | N:RB2=G3 | N:RB1=G2 | N:RB0=G1 |
| RXIN1D2 N/P | J:RC6=DE | J:RC5=VS | J:RC4=HS | J:RC3=B7 | J:RC2=B6 | J:RC1=B5 | J:RC0=B4 |
| RXIN2D2 N/P | N:RC6=DE | N:RC5=VS | N:RC4=HS | N:RC3=B5 | N:RC2=B4 | N:RC1=B3 | N:RC0=B2 |
| RXIN1D3 N/P | J:RD6=X | J:RD5=B1 | J:RD4=B0 | J:RD3=G1 | J:RD2=G0 | J:RD1=R1 | J:RD0=R0 |
| RXIN2D3 N/P | N:RD6=X | N:RD5=B7 | N:RD4=B6 | N:RD3=G7 | N:RD2=G6 | N:RD1=R7 | N:RD0=R6 |

6.3 Signal Description (CN1)

The module uses one LVDS receiver. LVDS is a differential signal technology for LCD interface and high speed data transfer device. The first LVDS port(RxOxxx) transmits odd pixels while the second LVDS port(RxExxx) transmits even pixels.

| Pin | Signal | Description |
|-----|-----------|--|
| 1 | RxOIN0- | Negative LVDS differential data input (Odd data) |
| 2 | RxOIN0+ | Positive LVDS differential data input (Odd data) |
| 3 | RxOIN1- | Negative LVDS differential data input (Odd data) |
| 4 | RxOIN1+ | Positive LVDS differential data input (Odd data) |
| 5 | RxOIN2- | Negative LVDS differential data input (Odd data, DSPTMG) |
| 6 | RxOIN2+ | Positive LVDS differential data input (Odd data, DSPTMG) |
| 7 | GND | Power Ground |
| 8 | RxOCLKIN- | Negative LVDS differential clock input (Odd clock) |
| 9 | RxOCLKIN+ | Positive LVDS differential clock input (Odd clock) |
| 10 | RxOIN3- | Negative LVDS differential data input (Odd data) |
| 11 | RxOIN3+ | Positive LVDS differential data input (Odd data) |
| 12 | RxEIN0- | Negative LVDS differential data input (Even data) |
| 13 | RxEIN0+ | Positive LVDS differential data input (Even data) |
| 14 | GND | Power Ground |
| 15 | RxEIN1- | Negative LVDS differential data input (Even data) |
| 16 | RxEIN1+ | Positive LVDS differential data input (Even data) |
| 17 | GND | Power Ground |
| 18 | RxEIN2- | Negative LVDS differential data input (Even data) |
| 19 | RxEIN2+ | Positive LVDS differential data input (Even data) |
| 20 | RxECLKIN- | Negative LVDS differential clock input (Even clock) |
| 21 | RxECLKIN+ | Positive LVDS differential clock input (Even clock) |
| 22 | RxEIN3- | Negative LVDS differential data input (Even data) |
| 23 | RxEIN3+ | Positive LVDS differential data input (Even data) |
| 24 | GND | Power Ground |
| 25 | AGBSEN | For AUO internal use |
| 26 | VDD | Power +3.3V |
| 27 | VDD | Power +3.3V |
| 28 | SCL | For AUO internal use |
| 29 | SDA | For AUO internal use |
| 30 | GND | Power Ground |



Product Specification

AU OPTRONICS CORPORATION

6.4 Interface Timing (LVDS)

6.4.1 Timing Characteristics

Basically, interface timings should match the 1920x1080/ 60Hz manufacturing guide line timing.

| Parameter | Symbol | Min. | Typ. | Max. | Unit | |
|--------------------|----------------------|----------|-------|------|--------|--------------------|
| Frame Rate | - | 60 | 60 | 60 | Hz | |
| Clock frequency | $1/T_{\text{Clock}}$ | 134 | 141.2 | 149 | MHz | |
| Horizontal Section | Period | T_H | 2046 | 2108 | 1920+B | T_{clock} |
| | Active | T_{HD} | 1920 | | | |
| | Blanking | T_{HB} | 126 | 188 | B | |
| Vertical Section | Period | T_V | 1092 | 1116 | 1080+A | T_{line} |
| | Active | T_{VD} | 1080 | | | |
| | Blanking | T_{VB} | 12 | 36 | A | |

Note1 : The above is as optimized setting

Note2 : DE mode only

Note3 : The maximum clock frequency = $[(1920 + B) * (1080 + A) * 60] < 149\text{MHz}$

Note4 : Clock frequency number is for reference, real setting value refer to EDID (Clock frequency 141.4 MHz)



6.4.2 Timing Diagram

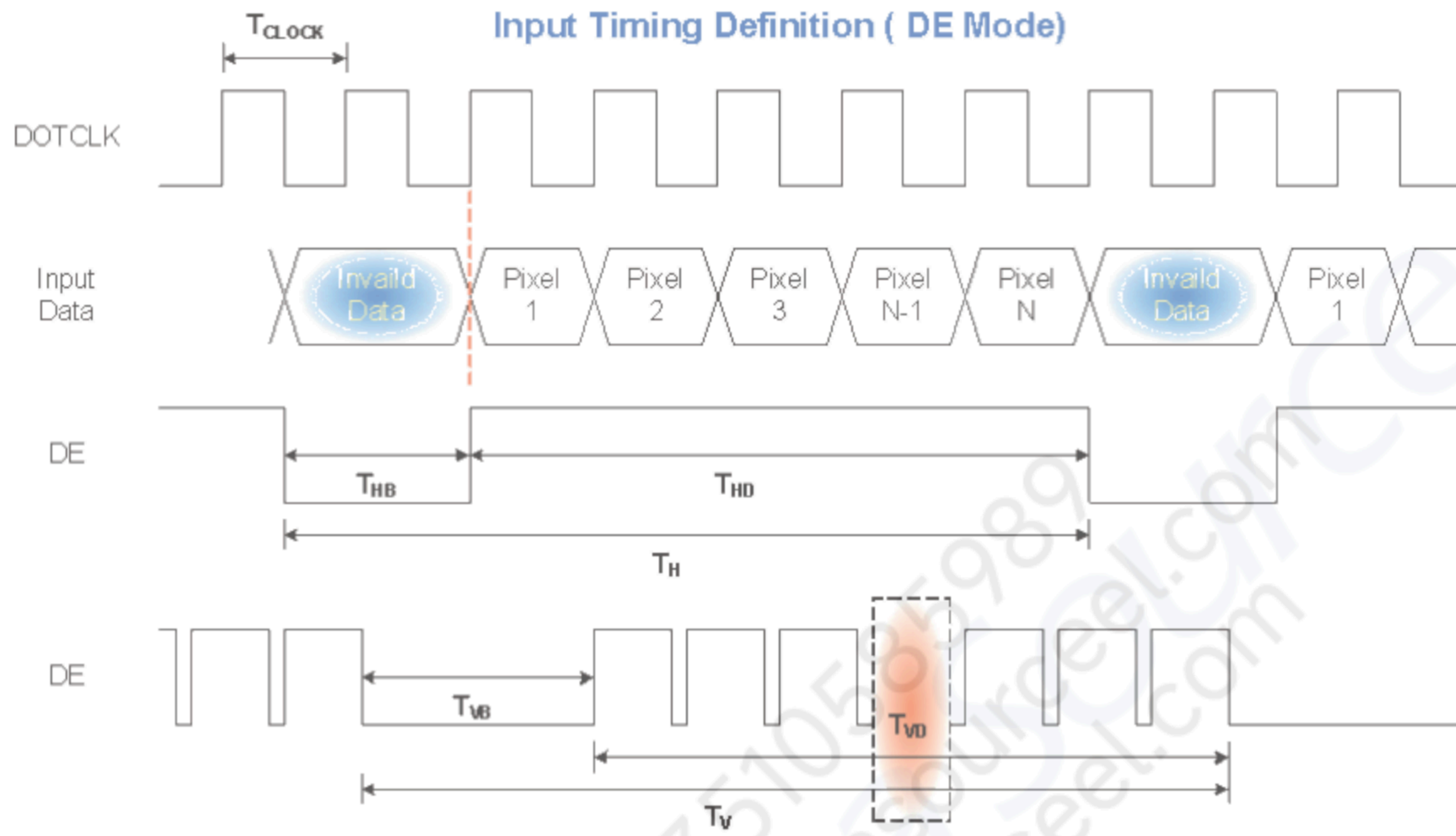

6.5 Power ON/OFF Sequence

VDD power and LED on/off sequence is as below. Interface signals are also shown in the chart. Signals from any system shall be Hi-Z state or low level when VDD is off.

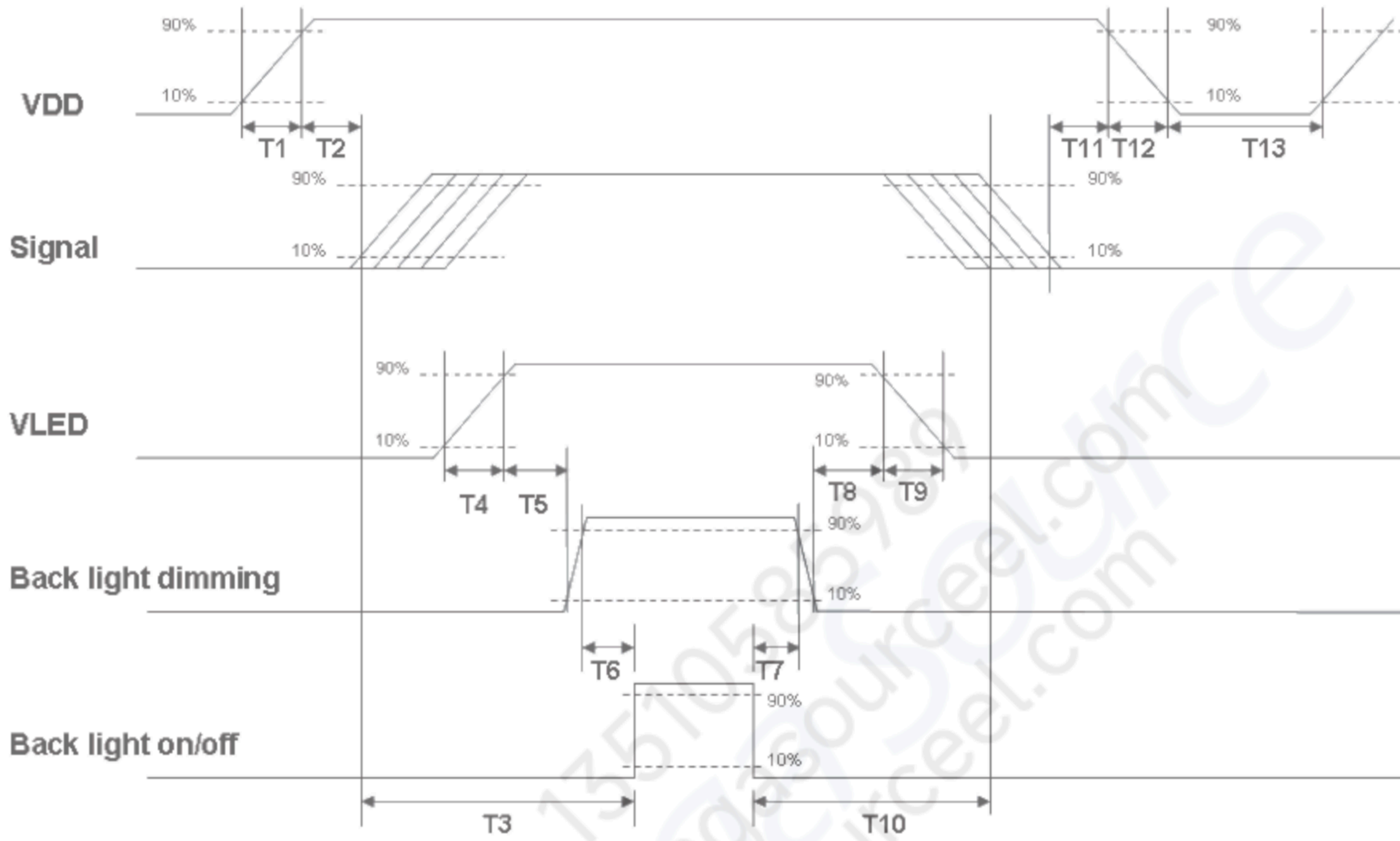

Power ON/OFF sequence timing

| Parameter | Value | | | Units |
|-----------|-------|------|------|-------|
| | Min. | Typ. | Max. | |
| T1 | 0.1 | - | 10 | [ms] |
| T2 | 200 | - | - | [ms] |
| T3 | 50 | - | - | [ms] |
| T4 | 0.5 | - | 10 | [ms] |
| T5 | 10 | - | - | [ms] |
| T6 | 10 | - | - | [ms] |
| T7 | 10 | - | - | [ms] |
| T8 | 10 | - | - | [ms] |
| T9 | 0.5 | - | 10 | [ms] |
| T10 | 50 | - | - | [ms] |
| T11 | 10 | - | - | [ms] |
| T12 | - | - | 10 | [ms] |
| T13 | 1000 | - | - | [ms] |

The above on/off sequence should be applied to avoid abnormal function in the display. Please make sure to turn off the power when you plug the cable into the input connector or pull the cable out of the connector.

7. Connector & Pin Assignment

Physical interface is described as for the connector on module. These connectors are capable of accommodating the following signals and will be following components.

7.1 TFT LCD Module

7.1.1 Connector(CN1)

| Connector Name / Designation | Interface Connector / Interface card |
|------------------------------|--|
| Manufacturer | Hirose |
| Type Part Number | DF19K-30P-1H (54) |
| Mating Housing Part Number | DF19G-30S-1C(05) DF19A-2830SCFA(41) |

7.1.2 Pin Assignment(CN1)

| Pin# | Signal Name | Pin# | Signal Name |
|------|-------------|------|-------------|
| 1 | RxOIN0- | 2 | RxOIN0+ |
| 3 | RxOIN1- | 4 | RxOIN1+ |
| 5 | RxOIN2- | 6 | RxOIN2+ |
| 7 | GND | 8 | RxOCLKIN- |
| 9 | RxOCLKN+ | 10 | RxOIN3- |
| 11 | RxOIN3+ | 12 | RxEIN0- |
| 13 | RxEIN0+ | 14 | GND |
| 15 | RxEIN1- | 16 | RxEIN1+ |
| 17 | GND | 18 | RxEIN2- |
| 19 | RxEIN2+ | 20 | RxECLKIN- |
| 21 | RxECLKIN+ | 22 | RxEIN3- |
| 23 | RxEIN3+ | 24 | GND |
| 25 | AGBSEN | 26 | VDD |
| 27 | VDD | 28 | SCL |
| 29 | SDA | 30 | GND |



7.2 Backlight Unit

Physical interface is described as for the connector on module. These connectors are capable of accommodating the following signals and will be following components.

7.2.1 Connector (CN2)

| Connector Name / Designation | LED Connector |
|------------------------------|---------------------------------------|
| Manufacturer | Hirose |
| Type Part Number | DF19G-8P-1H(54) |
| Mating Housing Part Number | DF19G-8S-1C(05) DF19A-2830SCFA(41) |

7.2.2 LED Driver Connector Pin Assignment (CN2)

| Pin# | Symbol | Signal Name |
|------|---------|-------------------------|
| 1 | LED_EN | LED enable pin |
| 2 | LED_PWM | System PWM Single Input |
| 3 | NC | No connect |
| 4 | VLED | +12V |
| 5 | VLED | +12V |
| 6 | NC | No connect |
| 7 | GND | Ground |
| 8 | GND | Ground |



8. Panel Reliability Test

| Items | Required Condition | Note |
|-------------------------------|---|----------|
| Temperature Humidity Bias | Ta= 40°C, 90%RH, 300h | Note 1,2 |
| High Temperature Operation | Ta= 70°C , Dry, 300h | |
| Low Temperature Operation | Ta= 0°C, 300h | |
| High Temperature Storage | Ta= 70°C, Dry, 300h | |
| Low Temperature Storage | Ta= 0°C, 300h | |
| Thermal Shock Test | Ta=-20°C to 60°C, Duration at 30 min, 50 cycles | Note 1,2 |
| Vibration test(non-operation) | 1.5G, (10~200Hz~10, random), 30 mins/axis (X, Y, Z) | |
| Shock Test(non-operation) | 50G,20ms,Half-sine wave, (±X, ±Y, ±Z) | Note 1 |
| ESD | Contact Discharge: ±8 KV, 150pF(330Ω) 1sec, 8Points, 25times/point Air Discharge: ±15 KV, 150pF(330Ω) 1sec, 8Points, 25times/point | |

Note 1: According to EN 61000-4-2 , ESD class B: Some performance degradation allowed.
Self-recoverable. No data lost, No hardware failures.

Note 2:

- Water condensation is not allowed for each test items.
- Each test is done by new TFT-LCD module. Don't use the same TFT-LCD module repeatedly for reliability test.
- The reliability test is performed only to examine the TFT-LCD module capability.
- To inspect TFT-LCD module after reliability test, please store it at room temperature and room humidity for 24 hours at least in advance.
- No function failure occurs. Mura shall be ignored after high temperature reliability test

9. Label and Package

9.1 Shipping Label Format

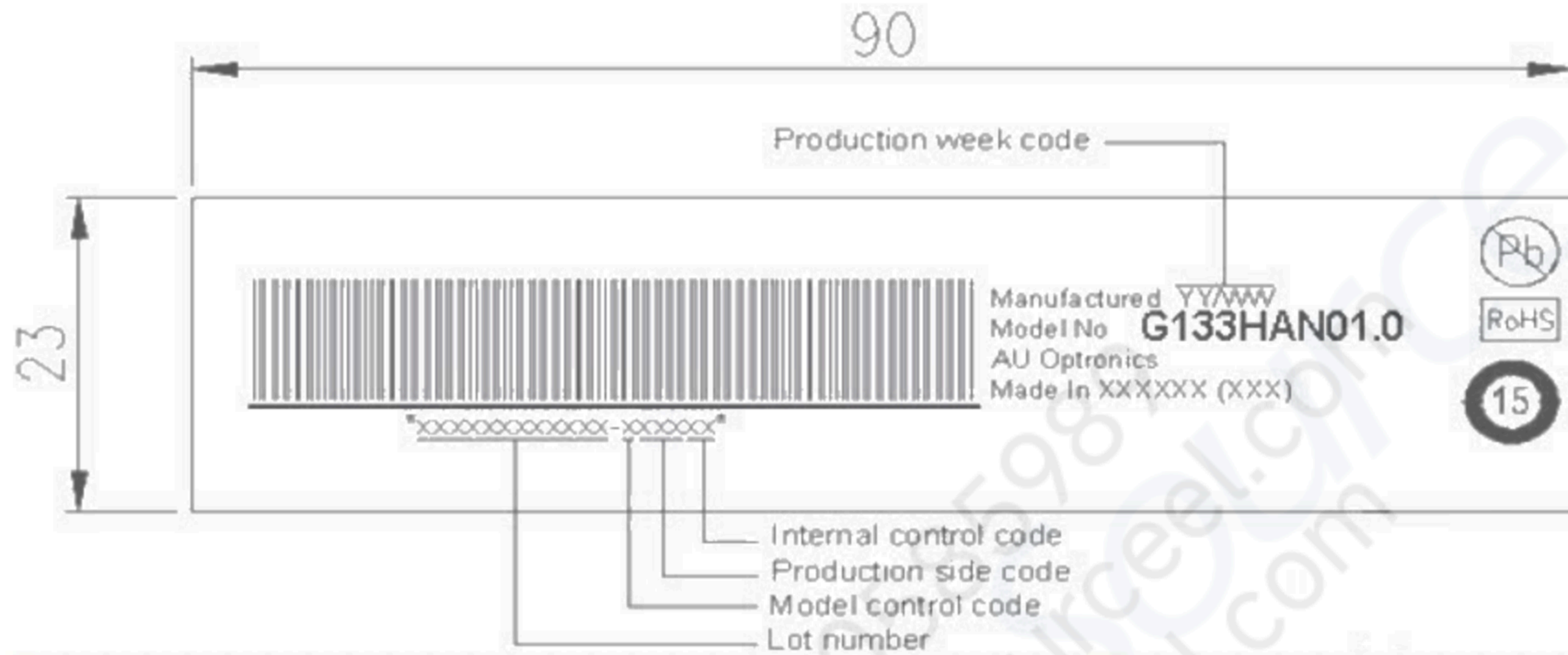

9.2 Carton Package

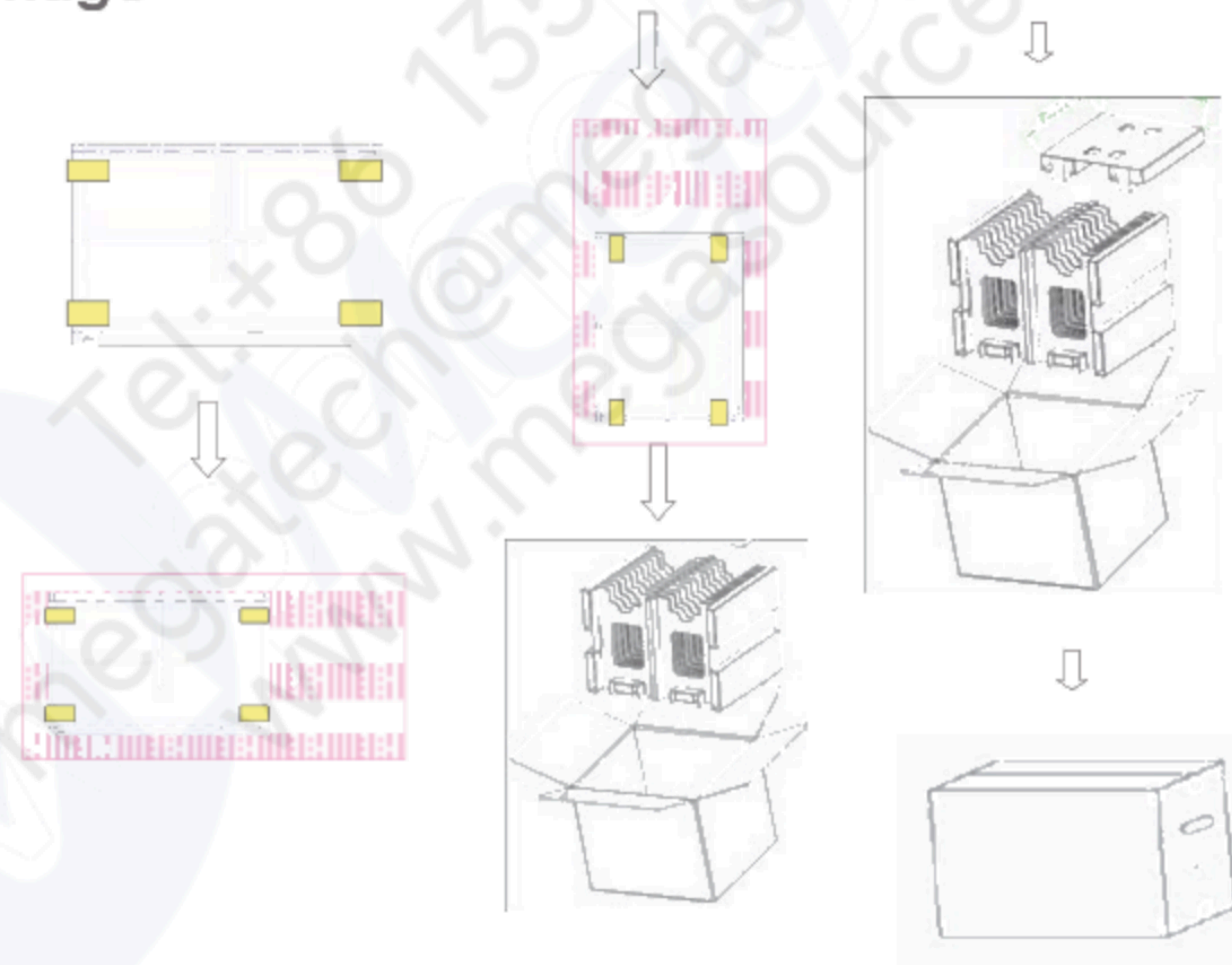

Max capacity : 20 TFT-LCD module per carton

Max weight: 10.5 kg per carton

Outside dimension of carton: 480mm(L)*275mm(W)*450mm(H)

Pallet size : 1150 mm * 910 mm * 132mm

Box stacked

Module by air : (2 *3) *3 layers , one pallet put 18 boxes , total 360pcs module

Module by sea : (2 *3) *3 layers+ one pallet (2 *3) *1 layer , total 480pcs module

Module by sea_HQ : (2 *3) *3 layers+ one pallet (2 *3) *1 layer , total 480pcs module



Product Specification

AU OPTRONICS CORPORATION

10 .Mechanical Characteristics

10.1 LCM Outline Dimension (Front View)





Product Specification

AU OPTRONICS CORPORATION

10.2 LCM Outline Dimension (Rear View)

