

PREPARED BY : DATE	SHARP	SPEC No. LD-14901
APPROVED BY : DATE		FILE No.
		ISSUE : Sep. 25.2002
		PAGE : 21 pages
	AVC LIQUID CRYSTAL DISPLAY GROUP SHARP CORPORATION	APPLICABLE GROUP AVC LIQUID CRYSTAL DISPLAY GROUP
	SPECIFICATION	

DEVICE SPECIFICATION FOR
TFT-LCD Module
 MODEL No.
LQ104V1DG21

CUSTOMER'S APPROVAL

DATE _____

BY _____

PRESENTED
 BY Makoto Takeda
 M. TAKEDA
 Department General Manager
 Development Engineering Department II
 AVC LIQUID CRYSTAL DISPLAY Division
 AVC LIQUID CRYSTAL DISPLAY GROUP
 SHARP CORPORATION

1. Application

This specification applies to color TFT-LCD module, LQ104V1DG21

(This specification is only applied for the module which has letter "A" at the end of the lot number of the module.)

These specification sheets are the proprietary product of SHARP CORPORATION("SHARP) and include materials protected under copyright of SHARP. Do not reproduce or cause any third party to reproduce them in any form or by any means, electronic or mechanical, for any purpose, in whole or in part, without the express written permission of SHARP .

The device listed in these specification sheets was designed and manufactured for use in general electronic equipment.

In case of using the device for applications such as control and safety equipment for transportation(aircraft, trains, automobiles, etc.), rescue and security equipment and various safety related equipment which require higher reliability and safety, take into consideration that appropriate measures such as fail-safe functions and redundant system design should be taken .

Do not use the device for equipment that requires an extreme level of reliability, such as aerospace applications, telecommunication equipment(trunk lines), nuclear power control equipment and medical or other equipment for life support .

SHARP assumes no responsibility for any damage resulting from the use of the device which does not comply with the instructions and the precautions specified in these specification sheets .

Contact and consult with a SHARP sales representative for any questions about this device .

2. Overview

This module is a color active matrix LCD module incorporating amorphous silicon TFT (Thin Film Transistor). It is composed of a color TFT-LCD panel, driver ICs, control circuit and power supply circuit and a backlight unit. Graphics and texts can be displayed on a 640×3×480 dots panel with 262,144 colors by supplying 18 bit data signal (6bit/color), four timing signals,+3.3V/ +5V DC supply voltage for TFT-LCD panel driving and supply voltage for backlight.

The TFT-LCD panel used for this module is a low-reflection and higher-color-saturation type. Therefore, this module is also suitable for the multimedia use.

Optimum viewing direction is 6 o'clock.

Backlight-driving DC/AC inverter is not built in this module.

3. Mechanical Specifications

Parameter	Specifications	Unit
Display size	26 (10.4") Diagonal	cm
Active area	211.2(H) × 158.4(V)	mm
Pixel format	640(H) × 480(V)	pixel
	(1 pixel = R + G + B dots)	
Pixel pitch	0.330(H) × 0.330(V)	mm
Pixel configuration	R,G,B vertical stripe	
Display mode	Normally white	
Unit outline dimensions *1	265.0(W) × 195.0(H) × 11.5max(D)	mm
Mass	700(max)	g
Surface treatment	Anti-glare and hard-coating 3H	

*1.Note: excluding backlight cables.

Outline dimensions is shown in Fig.1

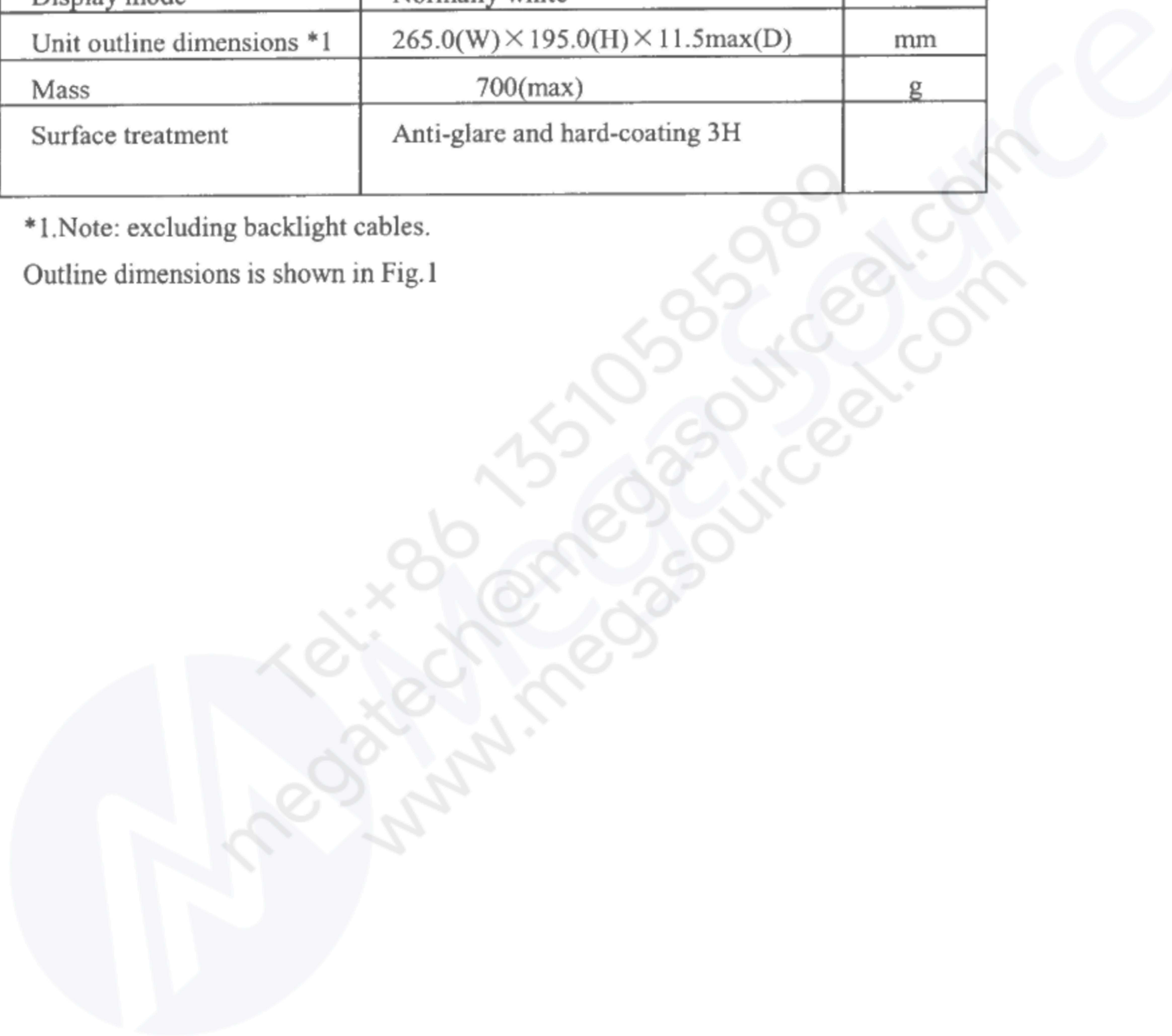

4. Input Terminals

4-1. TFT-LCD panel driving

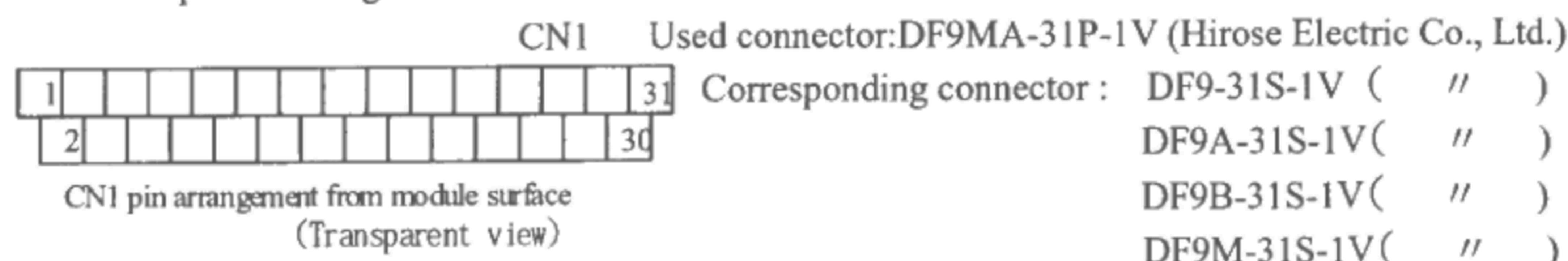

Pin No.	Symbol	Function	Remark
1	GND		
2	CK	Clock signal for sampling each data signal	
3	Hsync	Horizontal synchronous signal	【Note1】
4	Vsync	Vertical synchronous signal	【Note1】
5	GND		
6	R0	R E D data signal(LSB)	
7	R1	R E D data signal	
8	R2	R E D data signal	
9	R3	R E D data signal	
10	R4	R E D data signal	
11	R5	R E D data signal(MSB)	
12	GND		
13	G0	G R E E N data signal(LSB)	
14	G1	G R E E N data signal	
15	G2	G R E E N data signal	
16	G3	G R E E N data signal	
17	G4	G R E E N data signal	
18	G5	G R E E N data signal(MSB)	
19	GND		
20	B0	B L U E data signal(LSB)	
21	B1	B L U E data signal	
22	B2	B L U E data signal	
23	B3	B L U E data signal	
24	B4	B L U E data signal	
25	B5	B L U E data signal(MSB)	
26	GND		
27	ENAB	Signal to settle the horizontal display position	【Note2】
28	Vcc	+3.3/5.0V power supply	
29	Vcc	+3.3/5.0V power supply	
30	R/L	Horizontal display mode select signal	【Note3】
31	U/D	Vertical display mode select signal	【Note4】

※The shielding case is connected with GND.

【Note1】 480 line, 400 line or 350 line mode
is selected by the polarity combination
of the both synchronous signals.

Mode	480 lines	400 lines	350 lines
Hsync	Negative	Negative	Positive
Vsync	Negative	Positive	Negative

【Note2】 The horizontal display start timing is settled in
accordance with a rising timing of ENAB signal. In case ENAB is fixed "Low", the horizontal start timing is
determined as described in 7-2. Don't keep ENAB "High" during operation.

【Note3】 【Note4】

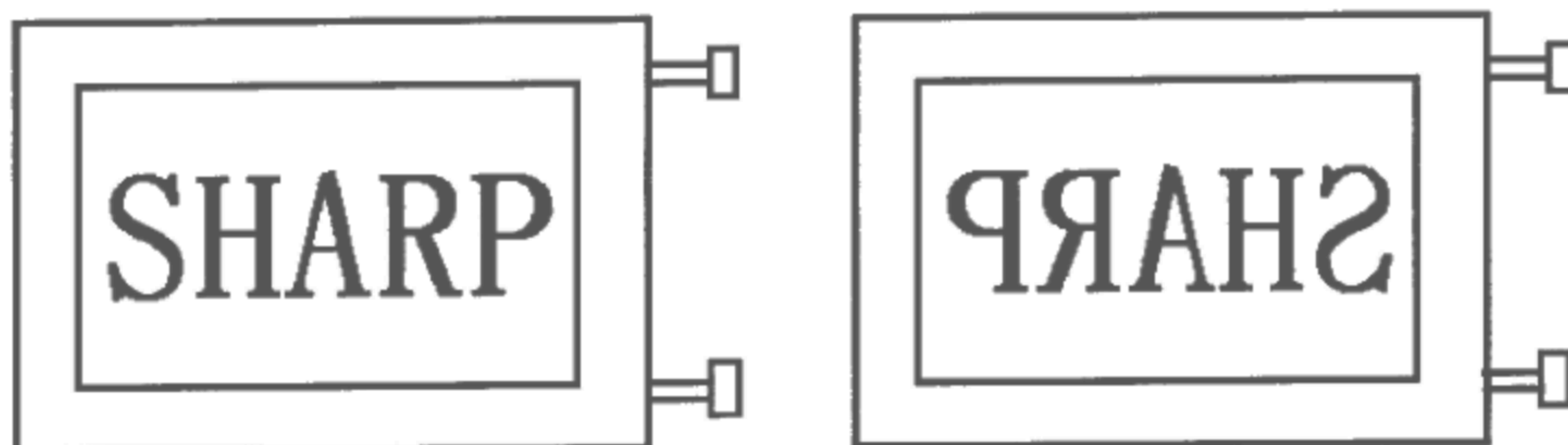

R/L=High、U/D=Low R/L=Low、U/D=Low

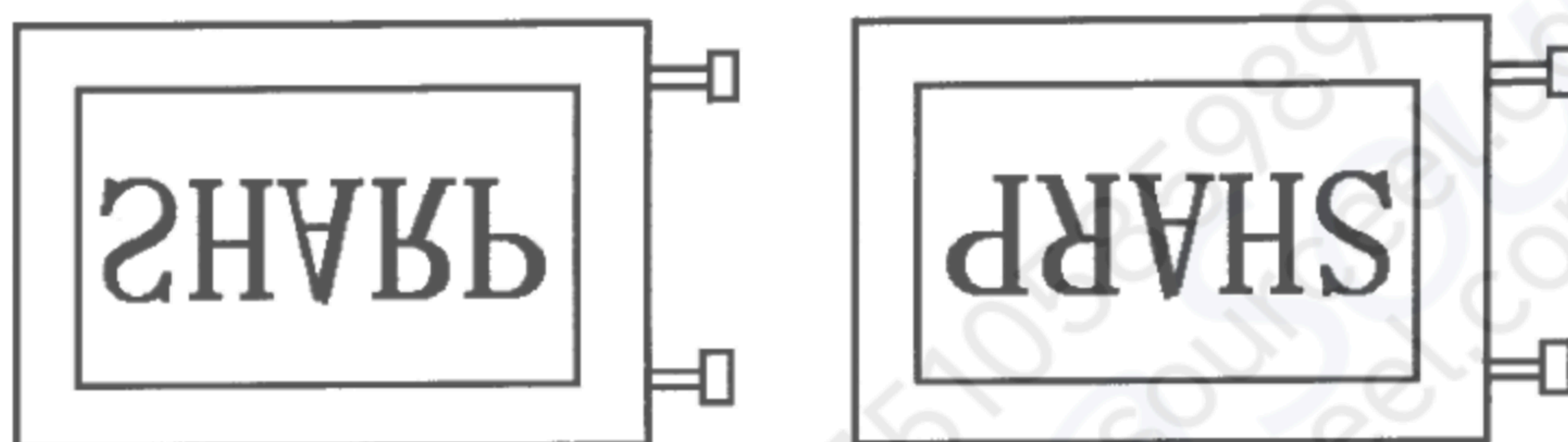

R/L=High、U/D=High R/L=Low、U/D=High

4-2. Backlight driving

Used connector : BHR-03VS-1(JST)

CN2、CN3

Corresponding connector :SM02(8.0)B-BHS(JST)

Pin no.	Symbol	Function
1	V _{HIGH}	Power supply for lamp (High voltage side)
2	NC	This is electrically opened.
3	V _{LOW}	Power supply for lamp (Low voltage side)

5. Absolute Maximum Ratings

Parameter	Symbol	Condition	Ratings	Unit	Remark
Input voltage	V _I	T _a =25°C	-0.3 ~ V _{CC} +0.3	V	【Note1】
+5V supply voltage	V _{CC}	T _a =25°C	0 ~ +6	V	
Storage temperature	T _{stg}	—	-30 ~ +70	°C	【Note2】
Operating temperature (Ambient)	T _{opa}	—	-10 ~ +65	°C	

【Note1】 CK,R0~R5,G0~G5,B0~B5,Hsync,Vsync,ENAB, R/L, U/L

【Note2】 Humidity : 95%RH Max. at T_a≤40°C.Maximum wet-bulb temperature at 39°C or less at T_a>40°C.

No condensation.

6. Electrical Characteristics

6-1. TFT-LCD panel driving

Ta=25°C

Parameter		Symbol	Min.	Typ.	Max.	Unit	Remark
Power Supply	Supply voltage	V _{CC}	+3.0	+3.3 +5.0	+5.5	V	【Note1】
	Current dissipation	I _{CC}	—	180	270	mA	V _{CC} =3.3V 【Note2】
I _{CC}		—	150	230	mA	V _{CC} =5.0V 【Note2】	
Permissive input ripple voltage		V _{RF}	—	—	100	mVp-p	
Input voltage (Low)		V _{IL}	—	—	0.3V _{CC}	V	【Note3】
Input voltage (High)		V _{IH}	0.7V _{CC}	—	—	V	
Input current (low)		I _{OL1}	—	—	1.0	μA	V _I =0V 【Note4】
		I _{OL2}	—	—	10	μA	V _I =0V 【Note5】
		I _{OL3}	—	—	800	μA	V _I =0V 【Note6】
Input current (High)		I _{OH1}	—	—	1.0	μA	V _I =V _{CC} 【Note7】
		I _{OH2}	—	—	300	μA	V _I =V _{CC} 【Note8】
		I _{OH3}	—	—	800	μA	V _I =V _{CC} 【Note9】

【NOTE 1】

V_{CC}-turn-on conditions

$$\begin{aligned}
 T1 &\leq 15 \text{ ms} \\
 0 < T2 &\leq 100 \text{ ms} \\
 0 < T3 &\leq 1 \text{ s} \\
 T4 &> 200 \text{ ms}
 \end{aligned}$$

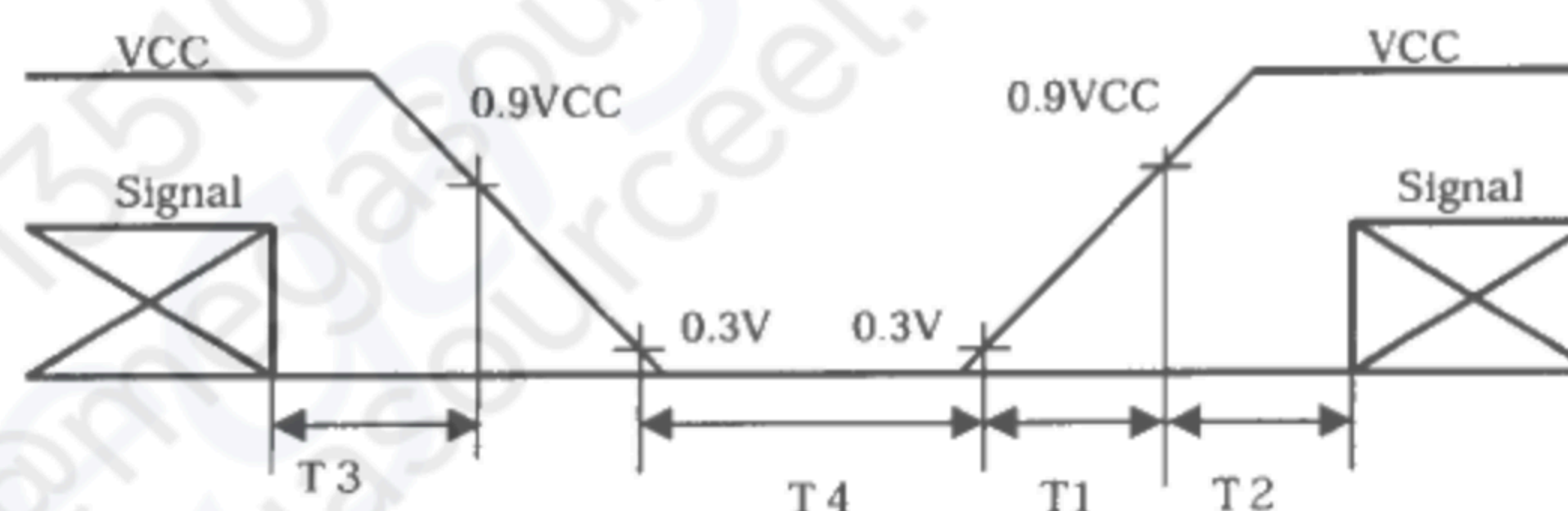
V_{CC}-dip conditions

$$\begin{aligned}
 1) \quad 2.5 \text{ V} &\leq V_{CC} \\
 T_d &\leq 10 \text{ ms} \\
 2) \quad V_{CC} &< 2.5 \text{ V}
 \end{aligned}$$

V_{CC}-dip condition should also follow
The V_{CC}-turn-on conditions

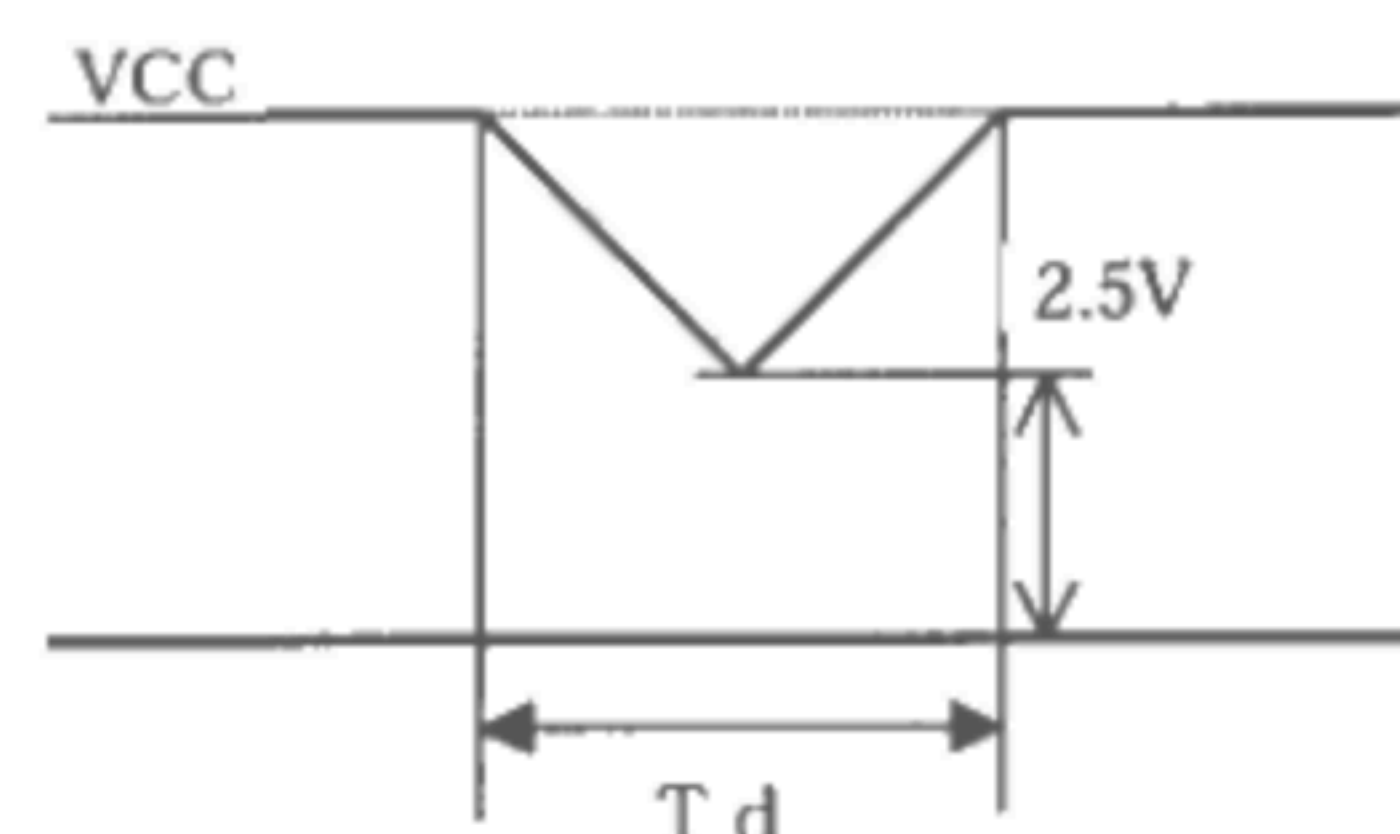

【Note2】 Typical current situation : 16-gray-bar pattern.

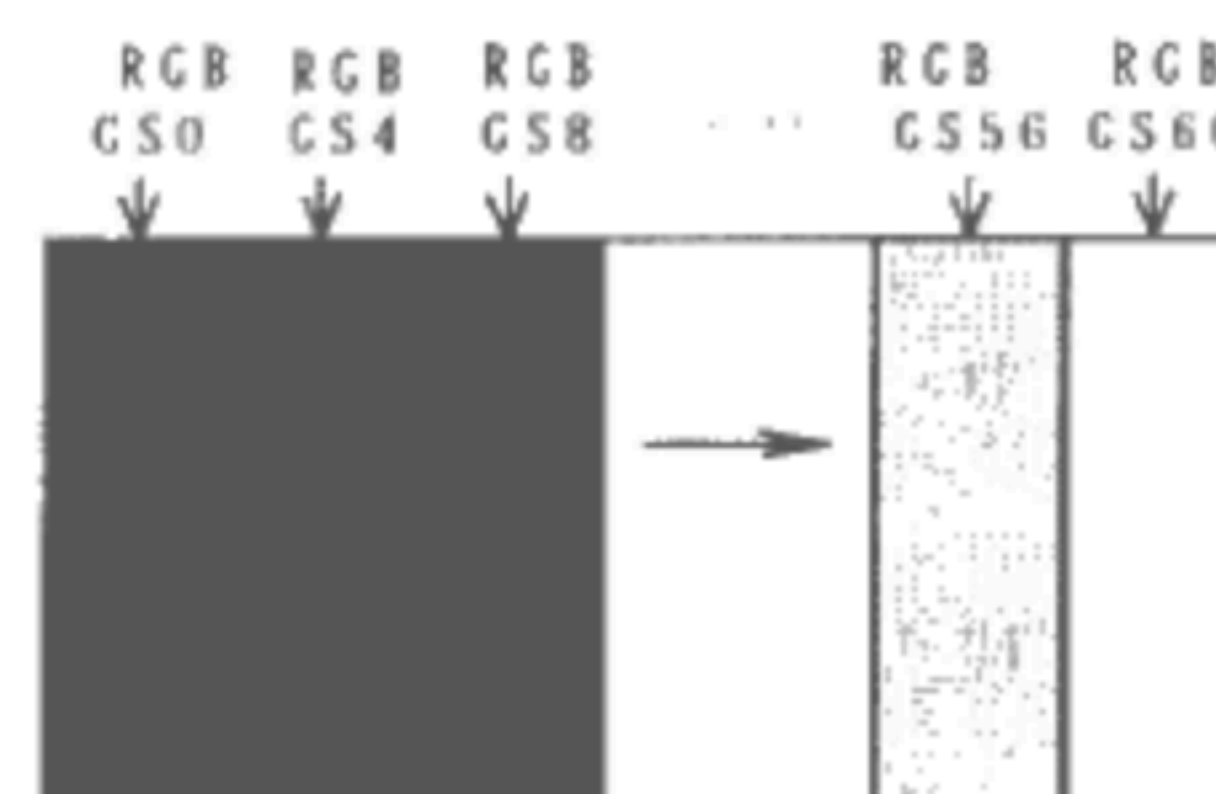
480 line mode/V_{CC}=+3.3V/+5.0V

【Note3】 CK, R0~R5, G0~G5, B0~B5, Hsync, Vsync, ENAB,
R/L, U/D

【Note4】 CK, R0~R5, G0~G5, B0~B5, Hsync, Vsync,

【Note5】 U/D, ENAB

【Note6】 R/L

【Note7】 CK, R0~R5, G0~G5, B0~B5, Hsync, Vsync, R/L

【Note8】 ENAB

【Note9】 U/D

6-2. Backlight driving

The backlight system is an edge-lighting type with double CCFT (Cold Cathode Fluorescent Tube). The characteristics of single lamp are shown in the following table.

$T_a=25^\circ\text{C}$

Parameter	Symbol	Min.	Typ.	Max.	Unit	Remark
Lamp current	I_L	2.0	6.0	6.5	mArms	【Note1】
Lamp power consumption	P_L	—	2.8	—	W	【Note2】
Lamp frequency	F_L	20	35	60	KHz	【Note3】
Kick-off voltage	V_s	—	—	950	Vrms	$T_a=25^\circ\text{C}$ 【Note4】
		—	—	1250	Vrms	$T_a=0^\circ\text{C}$ 【Note4】
		—	—	1500	Vrms	$T_a=-10^\circ\text{C}$ 【Note4】
Lamp life time	L_L	50000	—	—	hour	【Note5】

【Note1】 Lamp current is measured with current meter for high frequency as shown below.

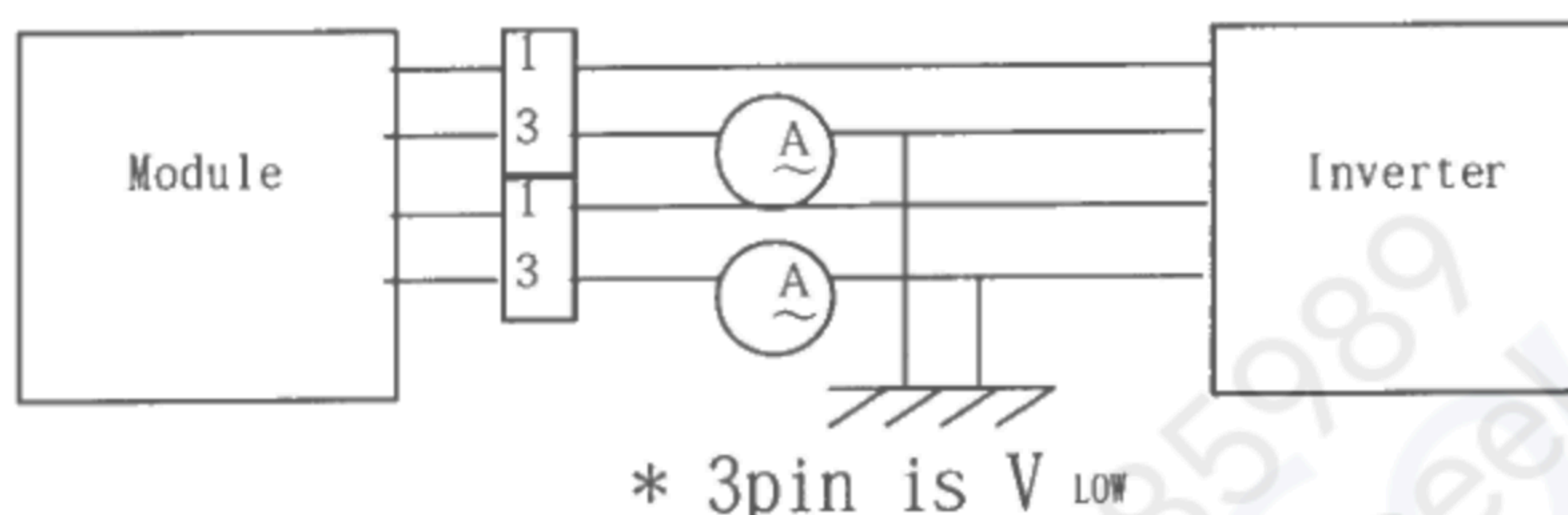

【Note2】 At the condition of $I_L=6.0\text{mArms}$

【Note3】 Lamp frequency may produce interference with horizontal synchronous frequency, and this may cause beat on the display. Therefore lamp frequency shall be detached as much as possible from the horizontal synchronous frequency and from the harmonics of horizontal synchronous to avoid interference.

【Note4】 The open output voltage of the inverter shall be maintained for more than 1sec; otherwise the lamp may not be turned on.

【Note5】 Since lamp is consumables, the life time written above is referencial value and it is not guaranteed in this specification sheet by SHARP.

Lamp life time is defined that it applied either ① or ② under this condition
(Continuous turning on at $T_a=25^\circ\text{C}$, $I_L=6.0\text{mArms}$)

① Brightness becomes 50% of the original value under standard condition.

② Kick-off voltage at $T_a=-10^\circ\text{C}$ exceeds maximum value, 1500Vrms.

In case of operating under lower temp environment, the lamp exhaustion is accelerated and the brightness becomes lower.

(Continuous operating under for around 1 month under lower temp condition may reduce the brightness to half of the original brightness.)

In case of such usage under lower temp environment, periodical lamp exchange is recommended.

【Note6】 The performance of the backlight, for example life time or brightness, is much influenced by the characteristics of the DC-AC inverter for the lamp. When you design or order the inverter, please make sure that a poor lighting caused by the mismatch of the backlight and the inverter (miss-lighting, flicker, etc.) never occur. when you confirm it, the module should be operated in the same condition as it is installed in your instrument.

【Note7】 It is required to have the inverter designed so that to allow the impedance deviation of the two CCFT lamps and the capacity deviation of barast capacitor.

7. Timing Characteristics of input signals

Timing diagrams of input signal are shown in Fig.2 - ①~③ .

7-1. Timing characteristics

Parameter		Symbol	Mode	Min.	Typ.	Max.	Unit	Remark
Clock	Frequency	1/Tc	all	—	25.18	28.33	MHz	
	High time	Tch	"	5	—	—	ns	
	Low time	Tcl	"	10	—	—	ns	
Data	Setup time	Tds	"	5	—	—	ns	
	Hold time	Tdh	"	10	—	—	ns	
Horizontal sync. signal	Cycle	TH	"	30.00	31.78	—	μs	
			"	750	800	900	clock	
	Pulse width	THp	"	2	96	200	clock	
Vertical sync. signal	Cycle	TV	480	515	525	560	line	
			400	446	449	480	line	
			350	447	449	510	line	
	Pulsewidth	TVp	all	1	—	34	line	
Horizontal display period		THd	"	640	640	640	clock	
Hsync-Clock phase difference		THc	"	10	—	Tc-10	ns	
Hsync-Vsync phase difference		TVh	"	0	—	TH-THp	clock	

Note) In case of lower frequency, the deterioration of display quality, flicker etc., may be occurred.

7-2. Horizontal display position

The horizontal display position is determined by ENAB signal and the input data corresponding to the rising edge of ENAB signal is displayed at the left end of the active area.

Parameter		symbol	Min.	Typ.	Max.	Unit	Remark
Enable signal	Setup time	Tes	5	—	Tc-10	ns	
	Pulse width	Tep	2	640	640	clock	
Hsync-Enable signal phase difference		THE	44	—	TH-664	clock	

Note) When ENAB is fixed "Low", the display starts from the data of C104(clock) as shown

in Fig.2-①~③. Be careful that the module does not work when ENAB is fixed "High".

When the phase difference is below 104 clock, keep the "High level of ENAB is signal longer Than 104-The. If it will not be kept, the display starts from the data of C104(clock).

7-3. Vertical display position

The vertical display position is automatically centered in the active area at each mode of VGA, 480-, 400-, and 350-line mode. Each mode is selected depending on the polarity of the synchronous signals described in 4-1(Note1).

In each mode, the data of TVn is displayed at the top line of the active area. And the display position will be centered on the screen like the following figure when the period of vertical synchronous signal, TV, is typical value.

In 400-, and 350-line mode, the data in the vertical data invalid period is also displayed, So, inputting all data "0" is recommended during vertical data invalid period.

ENAB signal has no relation to the vertical display position.

Mode	V-data start(TVs)	V-data period(TVd)	V-display start(TVn)	V-display period	Unit	Remark
480	34	480	34	480	line	
400	34	400	443-TV	480	line	
350	61	350	445-TV	480	line	

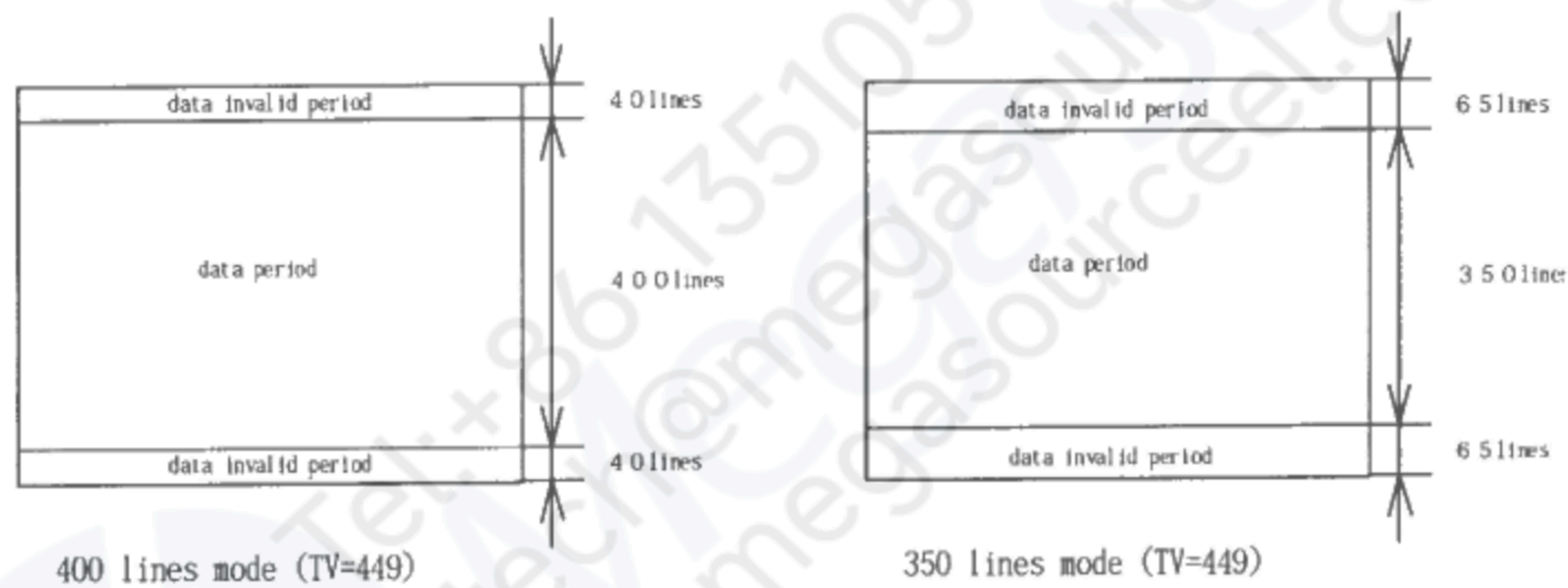

7-4. Input Data Signals and Display Position on the screen

Display position of input data (480 lines mode)
(H, V)

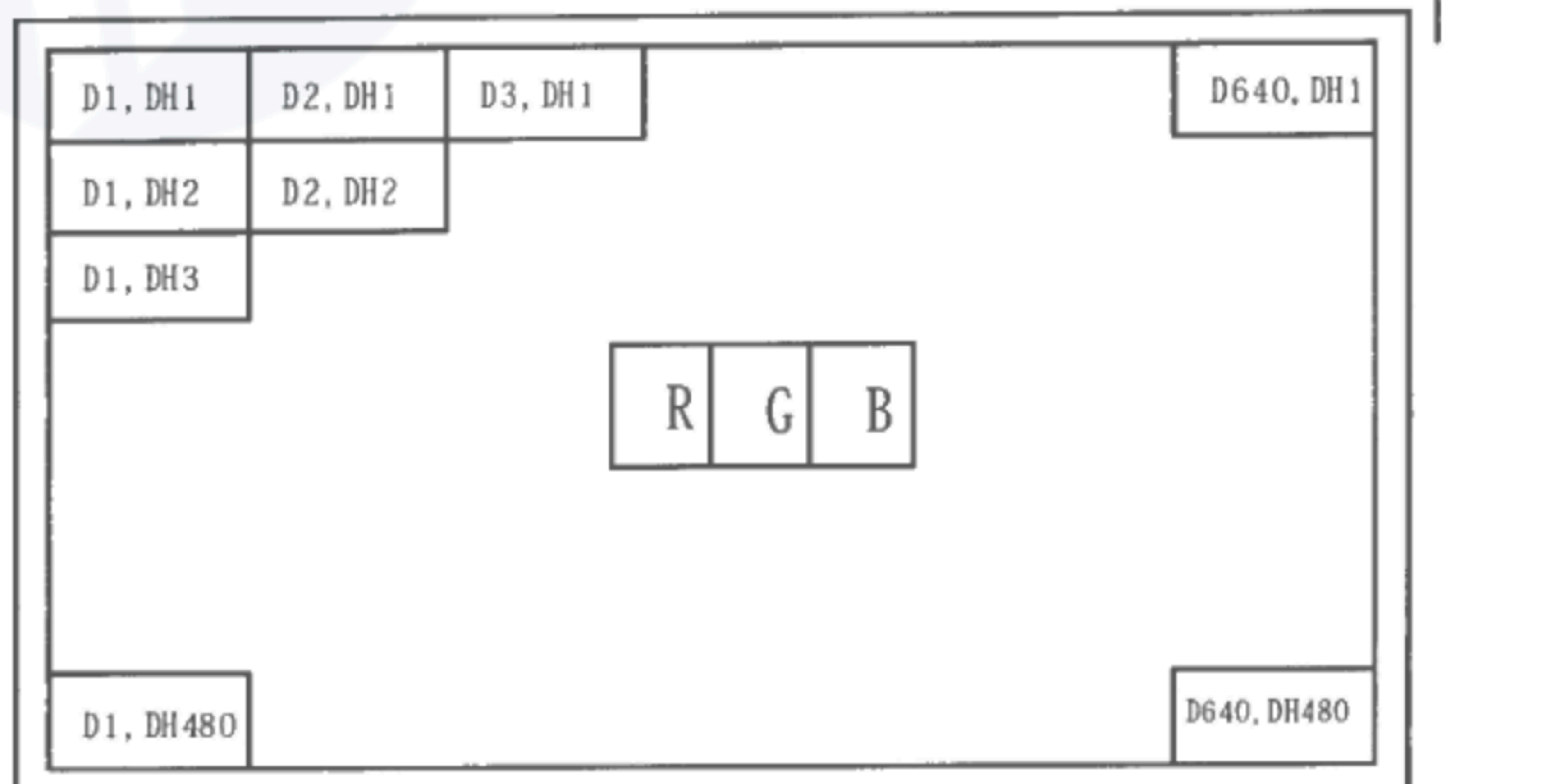

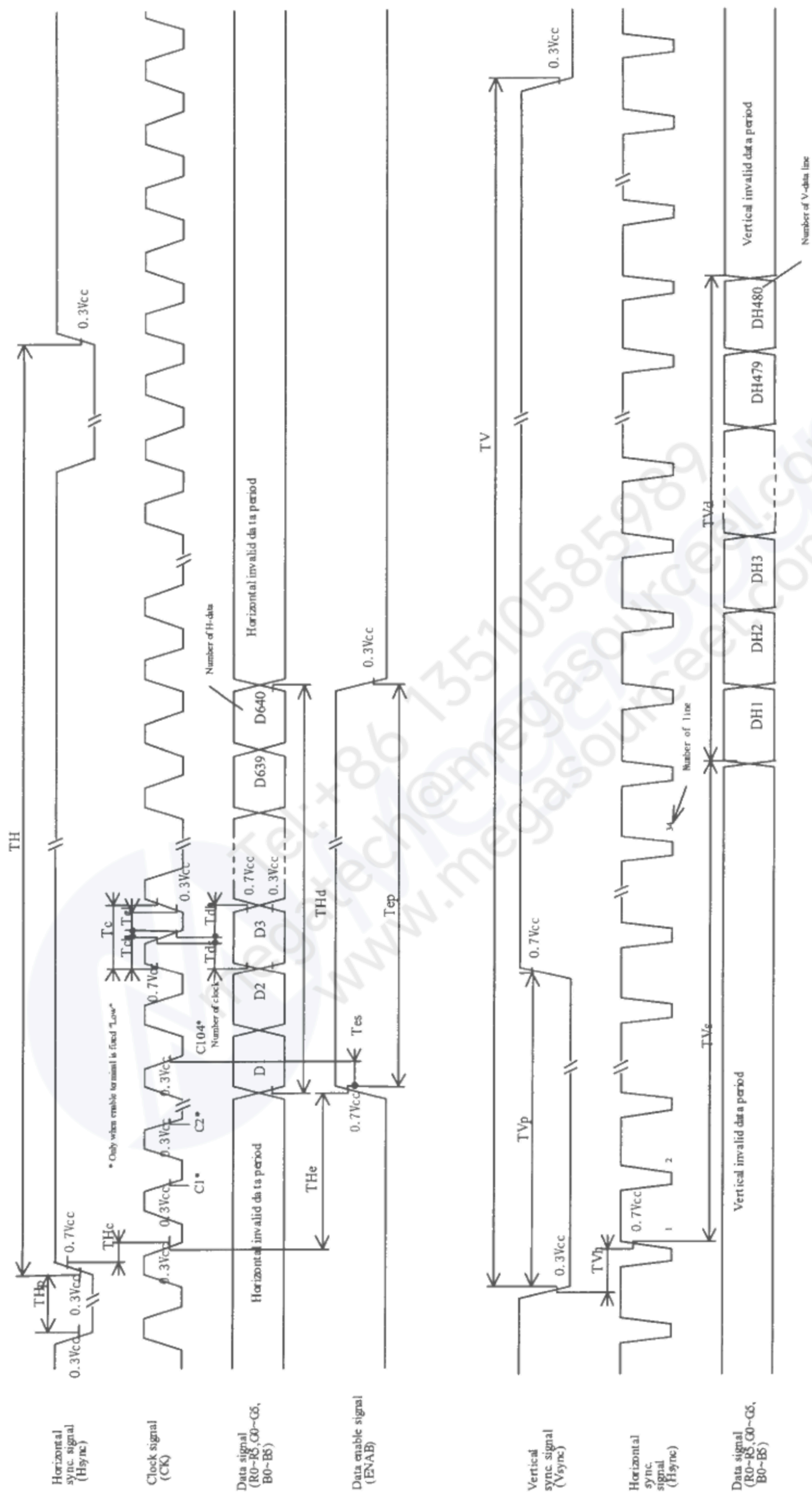

Fig 2-1 Input signal waveforms (480 line mode)

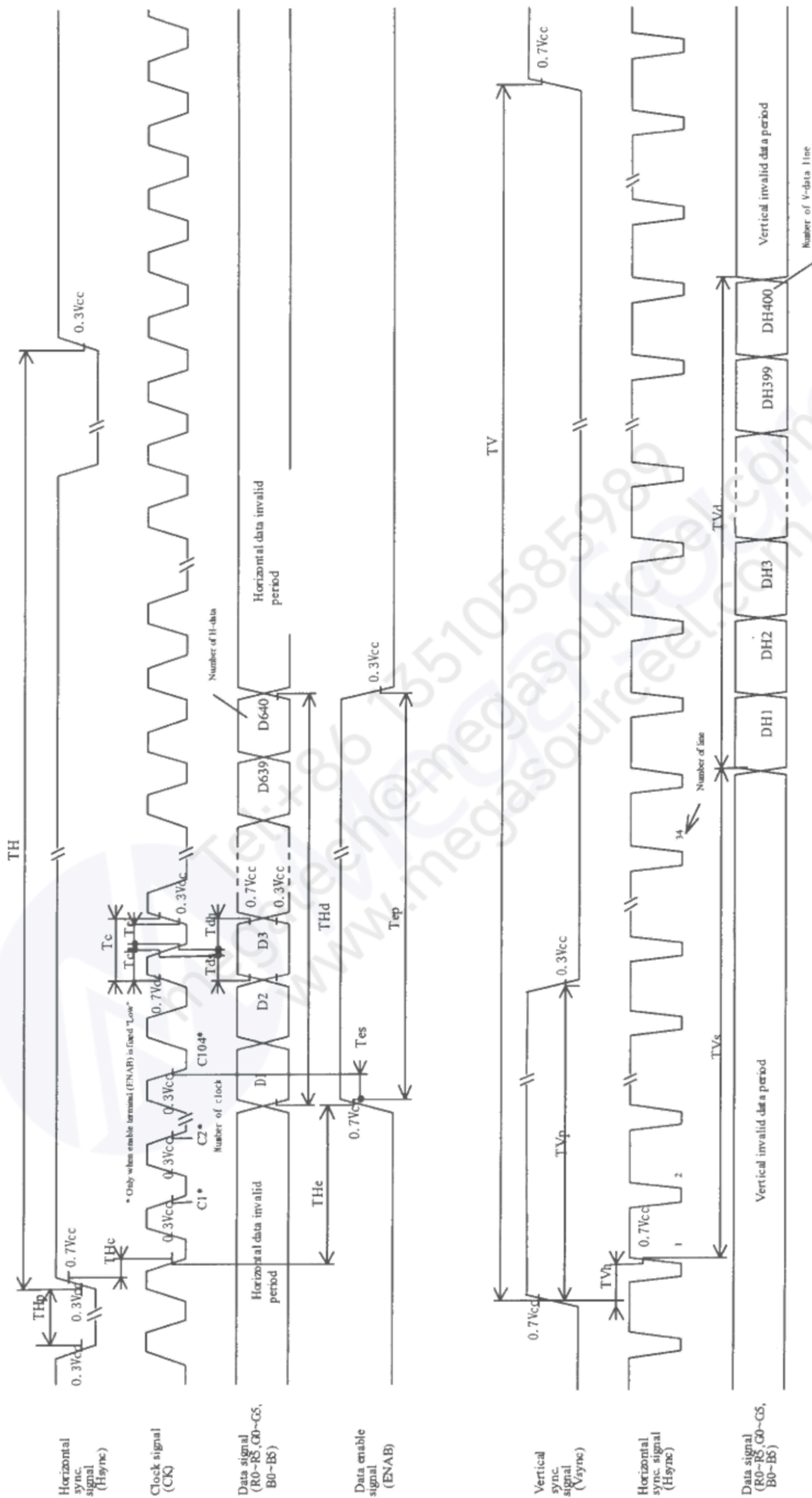

Fig.2-2 Input signal waveforms (400 line mode)

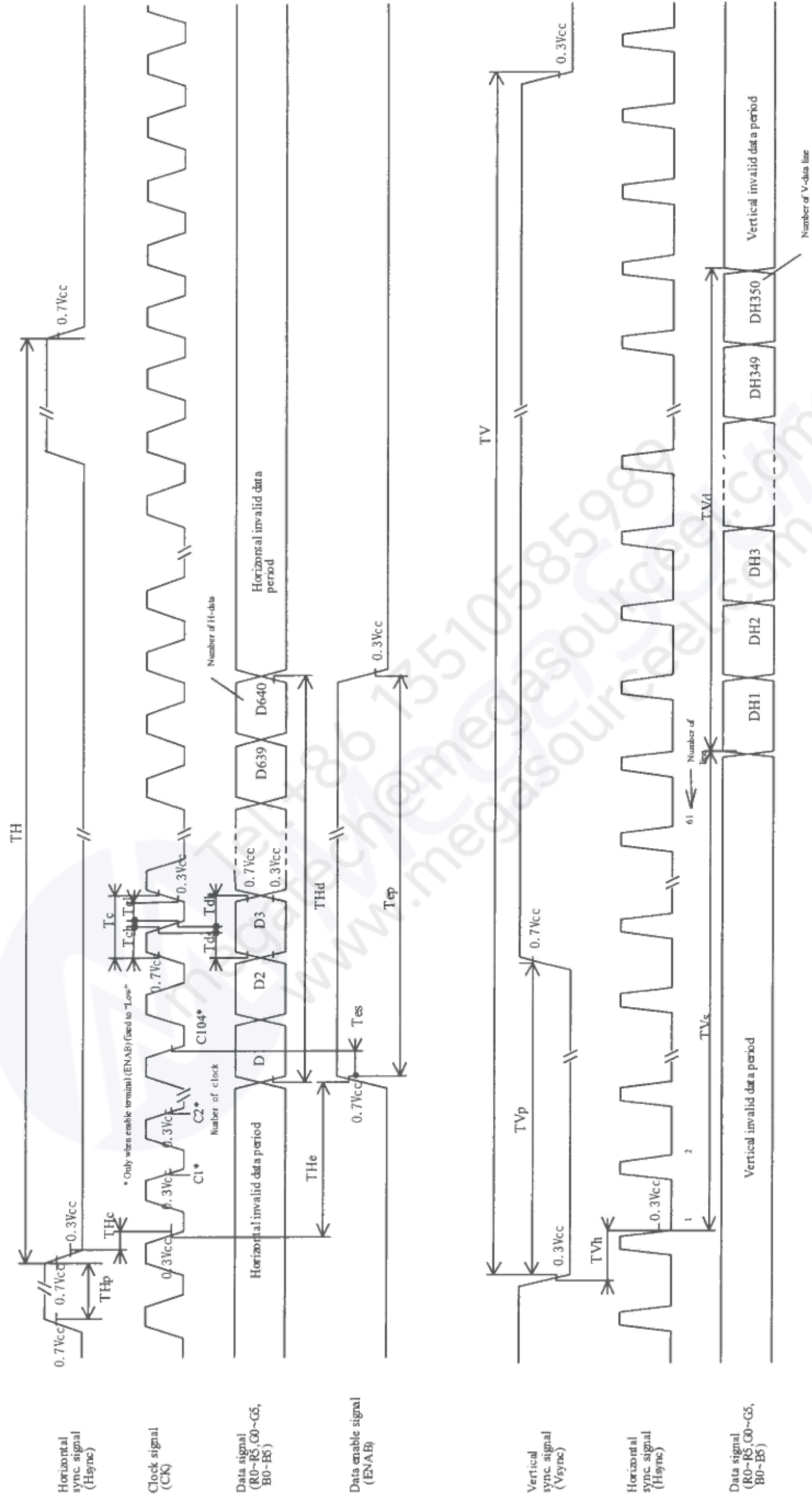

Fig.2-3 Input signal waveforms (350 line mode)

8. Input Signals, Basic Display Colors and Gray Scale of Each Color

	Colors & Gray scale	Data signal																		
		Gray Scale	R0	R1	R2	R3	R4	R5	G0	G1	G2	G3	G4	G5	B0	B1	B2	B3	B4	B5
Basic Color	Black	—	0	0	0	0	0	0	0	0	0	0	0	0	0	0	0	0	0	0
	Blue	—	0	0	0	0	0	0	0	0	0	0	0	0	1	1	1	1	1	1
	Green	—	0	0	0	0	0	0	1	1	1	1	1	1	0	0	0	0	0	0
	Cyan	—	0	0	0	0	0	0	1	1	1	1	1	1	1	1	1	1	1	1
	Red	—	1	1	1	1	1	1	0	0	0	0	0	0	0	0	0	0	0	0
	Magenta	—	1	1	1	1	1	1	0	0	0	0	0	0	1	1	1	1	1	1
	Yellow	—	1	1	1	1	1	1	1	1	1	1	1	1	0	0	0	0	0	0
	White	—	1	1	1	1	1	1	1	1	1	1	1	1	1	1	1	1	1	1
Gray Scale of Red	Black	GS0	0	0	0	0	0	0	0	0	0	0	0	0	0	0	0	0	0	0
	↑	GS1	1	0	0	0	0	0	0	0	0	0	0	0	0	0	0	0	0	0
	Darker	GS2	0	1	0	0	0	0	0	0	0	0	0	0	0	0	0	0	0	0
	↑	↓				↓					↓							↓		
	↓	↓				↓					↓							↓		
	Brighter	GS61	1	0	1	1	1	1	0	0	0	0	0	0	0	0	0	0	0	0
	↓	GS62	0	1	1	1	1	1	0	0	0	0	0	0	0	0	0	0	0	0
	Red	GS63	1	1	1	1	1	1	0	0	0	0	0	0	0	0	0	0	0	0
Gray Scale of Green	Black	GS0	0	0	0	0	0	0	0	0	0	0	0	0	0	0	0	0	0	0
	↑	GS1	0	0	0	0	0	0	1	0	0	0	0	0	0	0	0	0	0	0
	Darker	GS2	0	0	0	0	0	0	0	1	0	0	0	0	0	0	0	0	0	0
	↑	↓				↓					↓							↓		
	↓	↓				↓					↓							↓		
	Brighter	GS61	0	0	0	0	0	0	1	0	1	1	1	1	0	0	0	0	0	0
	↓	GS62	0	0	0	0	0	0	0	1	1	1	1	1	0	0	0	0	0	0
	Green	GS63	0	0	0	0	0	0	1	1	1	1	1	1	0	0	0	0	0	0
Gray Scale of Blue	Black	GS0	0	0	0	0	0	0	0	0	0	0	0	0	0	0	0	0	0	0
	↑	GS1	0	0	0	0	0	0	0	0	0	0	0	0	1	0	0	0	0	0
	Darker	GS2	0	0	0	0	0	0	0	0	0	0	0	0	0	1	0	0	0	0
	↑	↓				↓					↓							↓		
	↓	↓				↓					↓							↓		
	Brighter	GS61	0	0	0	0	0	0	0	0	0	0	0	0	1	0	1	1	1	1
	↓	GS62	0	0	0	0	0	0	0	0	0	0	0	0	0	1	1	1	1	1
	Blue	GS63	0	0	0	0	0	0	0	0	0	0	0	0	1	1	1	1	1	1

0 :Low level voltage, 1 : High level voltage

Each basic color can be displayed in 64 gray scales from 6 bit data signals. According to the combination of total 18 bit data signals, the 262,144-color display can be achieved on the screen.

9. Optical Characteristics

Ta=25°C, Vcc=+5V

Parameter		Symbol	Condition	Min	Typ	Max	Unit	Remark
Viewing Angle Range	Horizontal	$\theta 21, \theta 22$	C R > 1 0	60	70	—	Deg.	【Note1,4】
	Vertical	$\theta 11$		35	40	—	Deg.	
		$\theta 12$		55	70	—	Deg.	
Contrast ratio		C R	$\theta = 0^\circ$	150	—	—	—	【Note2,4】
			Optimum Viewing Angle	—	300	—	—	
Response Time	Rise	τr	$\theta = 0^\circ$	—	20	—	ms	【Note3,4】
	Decay	τd		—	40	—	ms	
Chromaticity of White		x		—	0.313	—		【Note4】 I _L =6.0mArms f=35kHz
		y		—	0.329	—		
Luminance of white		Y _L		280	350	—	cd/m ²	
White Uniformity		δ_w		—	—	1.45	—	【Note5】
Viewing Angle range as a Brightness Definition	Horizontal	$\theta 21, \theta 22$	50% of the maximum brightness	—	50	—	Deg.	【Note1】
	Vertical	$\theta 11$		—	40	—	Deg.	
		$\theta 12$		—	35	—	Deg.	

※The measurement shall be executed 30 minutes after lighting at rating. (condition:I_L=6.0mArms)

The optical characteristics shall be measured in a dark room or equivalent state with the method shown in Fig.3 below.

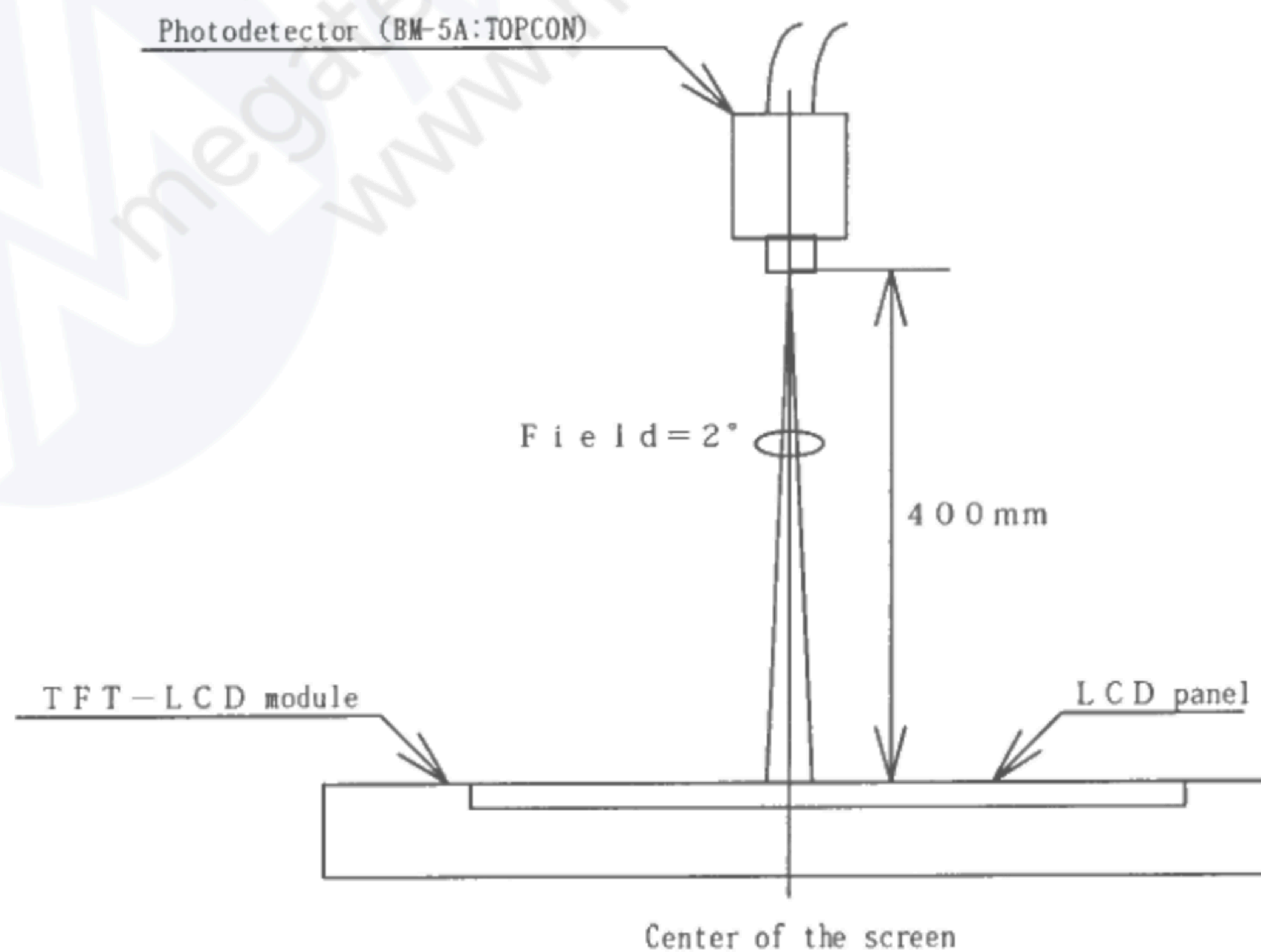
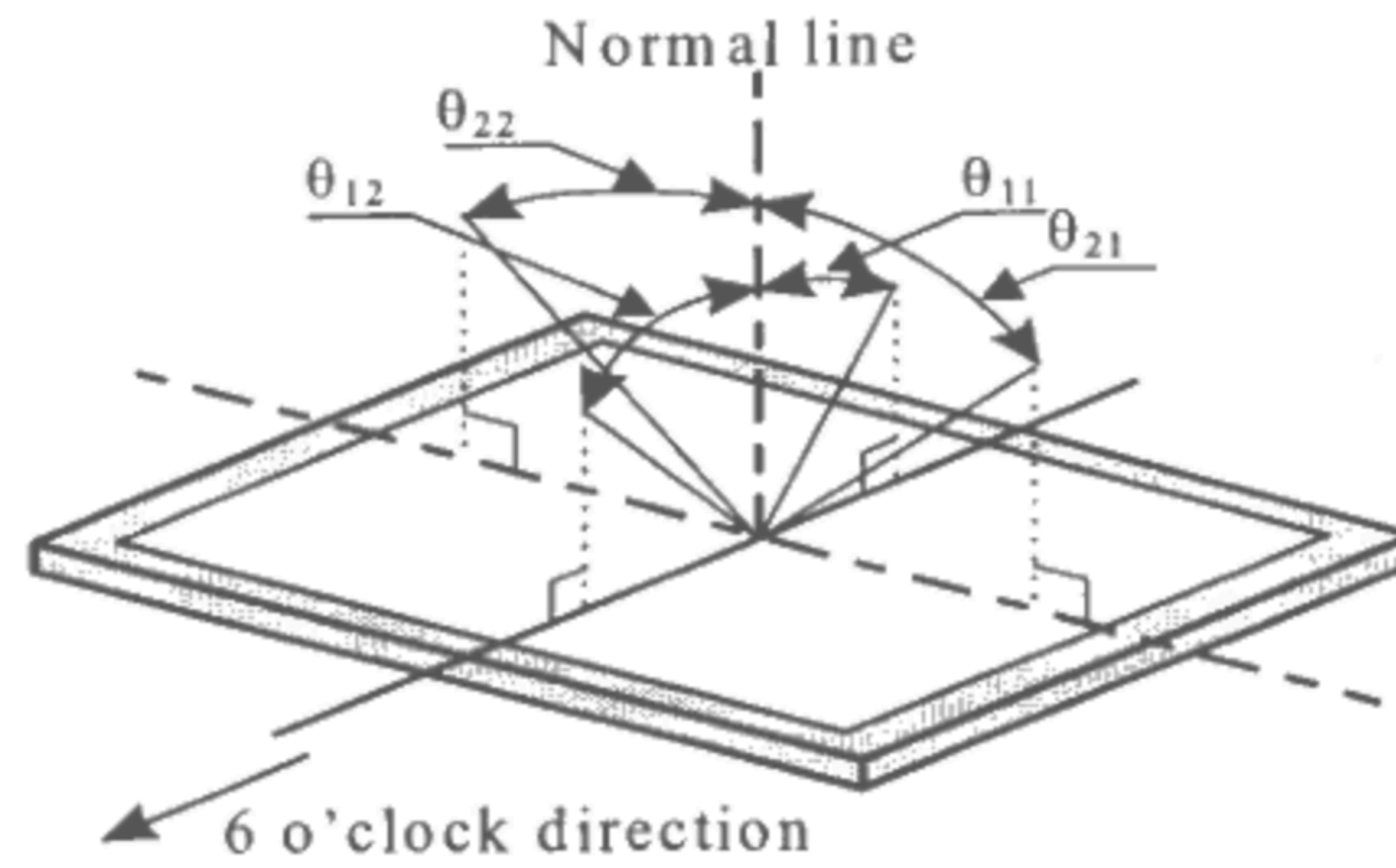

Fig.3 Optical characteristics measurement method

【Note1】 Definitions of viewing angle range:



【Note2】 Definition of contrast ratio:

The contrast ratio is defined as the following.

$$\text{Contrast Ratio (CR)} = \frac{\text{Luminance (brightness) with all pixels white}}{\text{Luminance (brightness) with all pixels black}}$$

【Note3】 Definition of response time:

The response time is defined as the following figure and shall be measured by switching the input signal for "black" and "white".

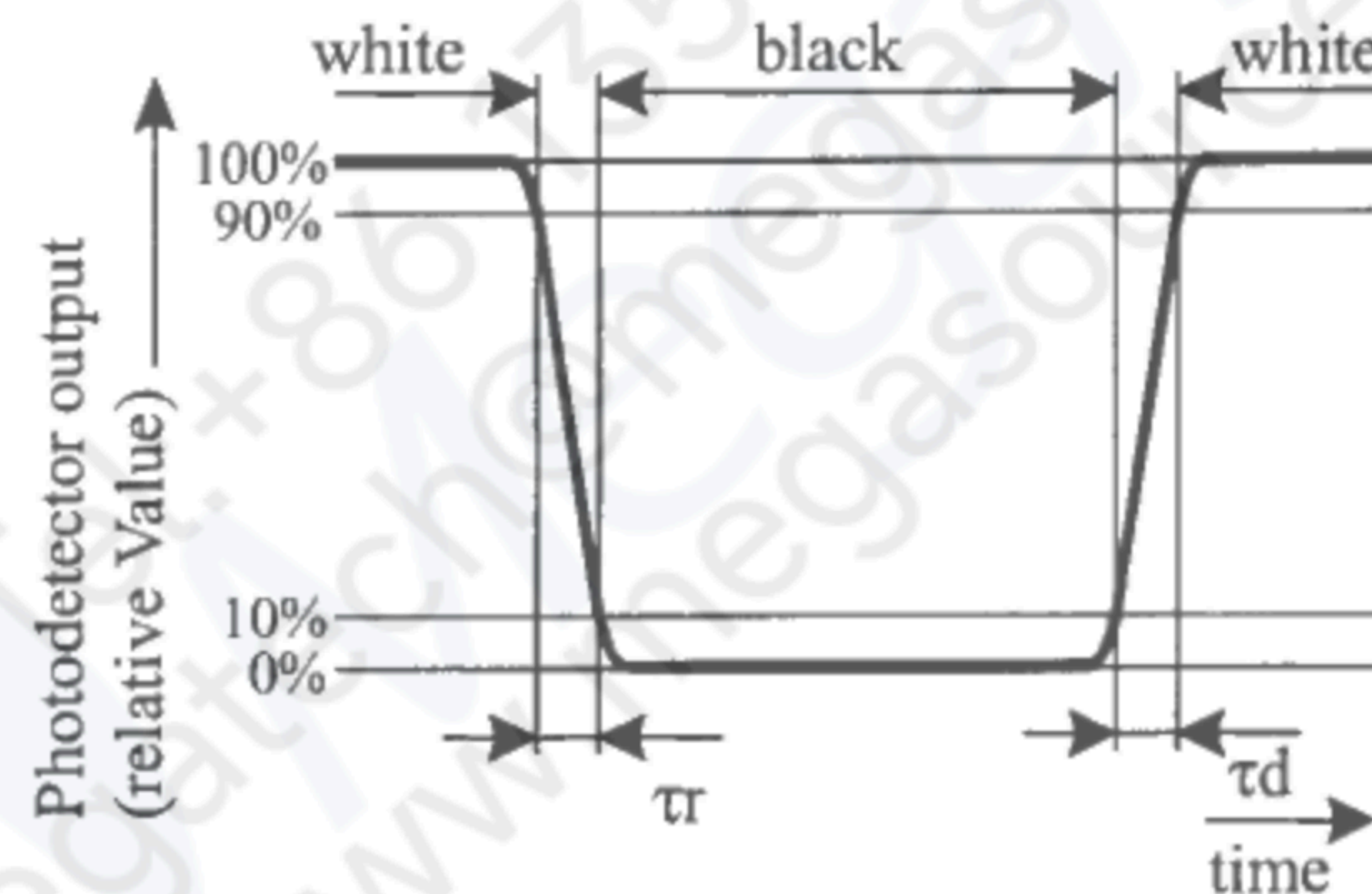

【Note4】 This shall be measured at center of the screen.

【Note5】 Definition of white uniformity:

White uniformity is defined as the following with five measurements (A~E).

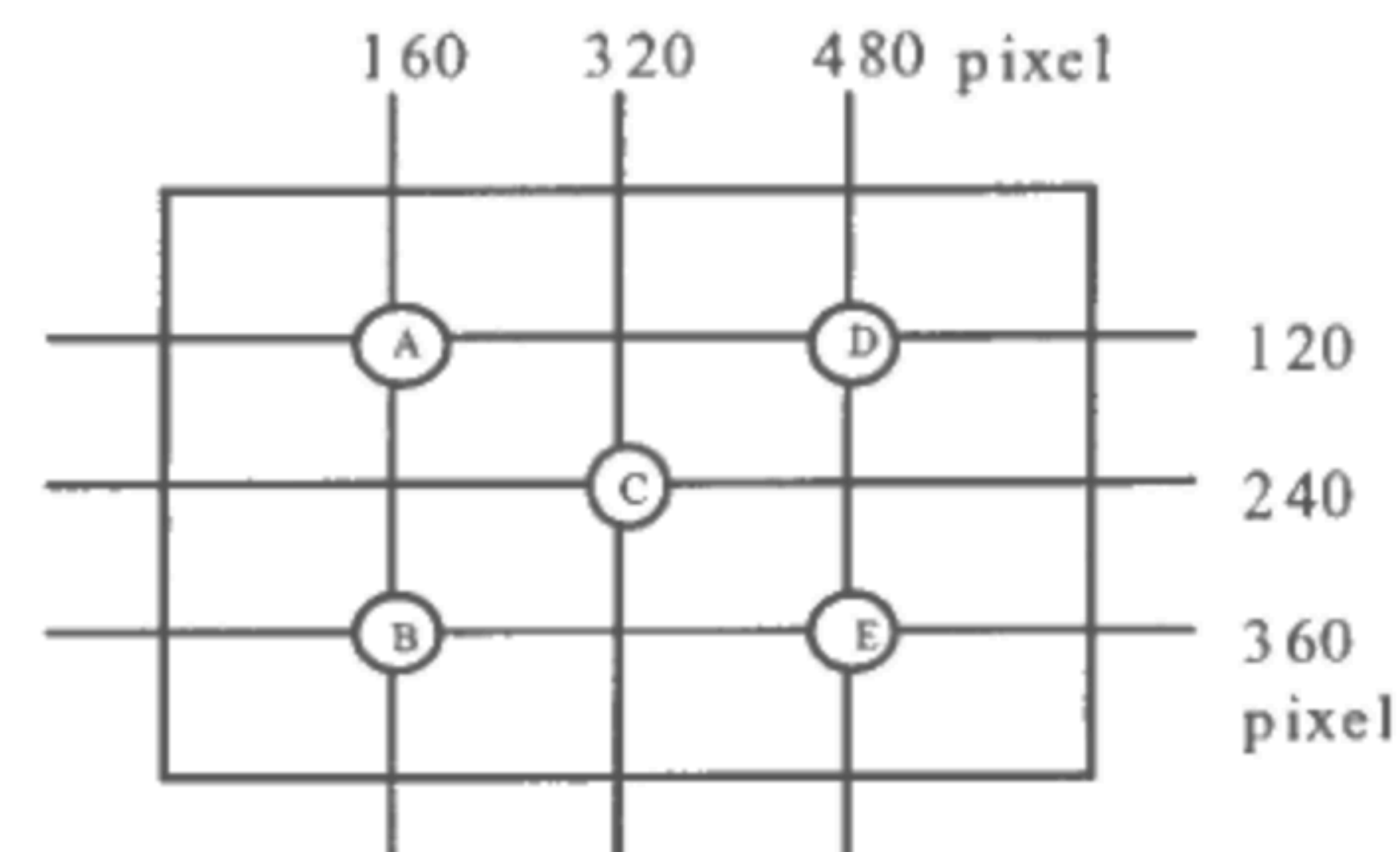

$$\delta_w = \frac{\text{Maximum Luminance of five points (brightness)}}{\text{Minimum Luminance of five points (brightness)}}$$

10. Display Quality

The display quality of the color TFT-LCD module shall be in compliance with the Incoming Inspection Standard.

11. Handling Precautions

- a) Be sure to turn off the power supply when inserting or disconnecting the cable.
- b) Be sure to design the cabinet so that the module can be installed without any extra stress such as warp or twist.
- c) Since the front polarizer is easily damaged, pay attention not to scratch it.
- d) Wipe off water drop immediately. Long contact with water may cause discoloration or spots.
- e) When the panel surface is soiled, wipe it with absorbent cotton or other soft cloth.
- f) Since the panel is made of glass, it may break or crack if dropped or bumped on hard surface.
Handle with care.
- g) Since CMOS LSI is used in this module, take care of static electricity and injure the human earth when handling.
- h) Protection film is attached to the module surface to prevent it from being scratched .
Peel the film off slowly , just before the use, with strict attention to electrostatic charges.
Blow off 'dust' on the polarizer by using an ionized nitrogen.
- i) The polarizer surface on the panel is treated with Anti-Glare for low reflection. In case of attaching protective board over the LCD,be careful about the optical interface fringe etc. which degrades display quality.
- j)Do not expose the LCD panel to direct sunlight. Lightproof shade etc. should be attached when LCD panel is used under such environment.
- k) Connect GND to 4 place of mounting holes to stabilize against EMI and external noise.
- l) There are high voltage portions on the backlight and very dangerous. Careless touch may lead to electrical shock. When exchange lamps or service,turn off the power without tail.
- m) When handling LCD modules and assembling them into cabinets, please be noted that long-term storage in the environment of oxidization or deoxidization gas and the use of such materials as reagent, solvent, adhesive, resin, etc. which generate these gasses, may cause corrosion and discoloration of the LCD modules.
- n)Cold cathode fluorescent lamp in LCD panel contains a small amount of mercury, please follow local ordinances or regulations for disposal.

12.Packing form

Product Country	JAPAN
Piling number of cartons	7 (Max)
Packing quantity in one carton	20
Carton size [mm]	525 (W)×309(D)×377(H)
Total mass of one carton filled with full modules	17.5kg
Packing form is shown	Fig.4

13. Reliability test items

No.	Test item	Conditions
1	High temperature storage test	Ta=70°C 240h
2	Low temperature storage test	Ta= -30°C 240h
3	High temperature & high humidity operation test	Ta=40°C ; 95%RH 240h (No condensation)
4	High temperature operation test	Ta=65°C 240h
5	Low temperature operation test	Ta= -10°C 240h
6	Vibration test (non- operating)	Frequency: 10~57Hz/Vibration width (one side):0.075mm : 58~500Hz/Gravity:9.8m/s ² Sweep time : 11 minutes Test period : 3 hours (1 hour for each direction of X,Y,Z)
7	Shock test (non- operating)	Max. gravity : 490m/s ² Pulse width : 11ms, half sine wave Direction : ±X,±Y,±Z once for each direction.

【Result Evaluation Criteria】

Under the display quality test conditions with normal operation state, these shall be no change which may affect practical display function.

14. Others

1) Label: Module

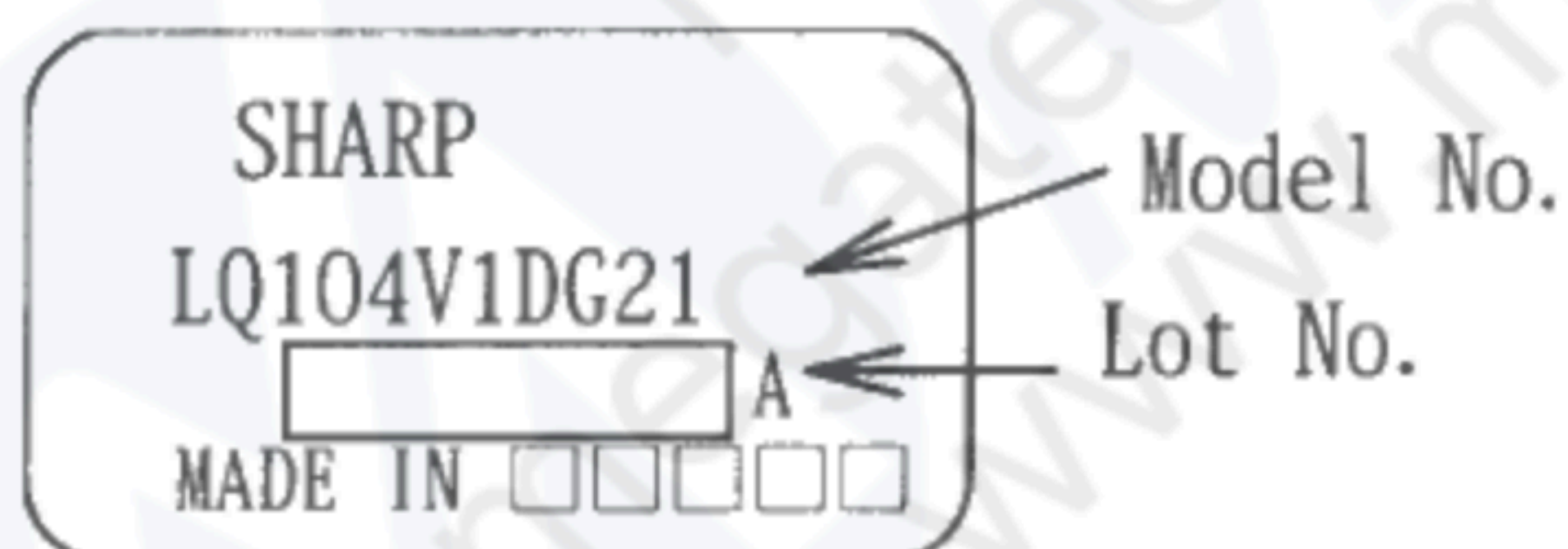

Packing box

①Model.No ②Shipment Date ③Quantity

社内品番: (4 S) LQ104V1DG21 ①	
LotNO. : (1T) 2002. 9. 1 ②	
Quantity: (Q) 20 pcs ③	
ユーザ品番 :	
シャープ物流用ラベルです。	

2) Adjusting volume have been set optimally before shipment, so do not change any adjusted value.

If adjusted value is changed, the specification may not be satisfied.

3) Disassembling the module can cause permanent damage and should be strictly avoided.

4) Please be careful since image retention may occur when a fixed pattern is displayed for a long time

5) If any problem occurs in relation to the description of this specification , it shall be resolved through discussion with spirit of cooperation.

15. Procedure to backlight replacement

Lamp which is used in the LCD module is consumable goods. When the lamp replacement is needed due to the expiry of lamp-operating life, make sure that the power supply is turned off before the lamp replacement. Since there is high-voltage current in the backlight area, an electric shock is likely to happen if the lamp is replaced without turning off the power supply. The lamp replacement can be conducted by either horizontal slide method or backside exchange.

(1) By horizontal slide (See figure #5 & figure #6)

- 1) Pull-out the lamp unit to the direction which arrow "F" indicates by pressing the white latch of the plastic lamp unit by using small flat-blade screwdriver to the either direction of "A" or "B" as shown in the figure #5.
- 2) Out of the 2 pcs of lamp units (2pcs/set), insert the replacement lamp which has triangle mark on the side of the lamp unit into the slot of the metal area of LCD module which also has triangle mark. And then, insert the remaining lamp unit which does not have triangle mark into the slot of the metal area of LCD module which also does not have triangle mark. During the insertion, lamp unit can be inserted smoothly by pressing the transparent resin (light guide sheet) inside the LCD module by using the end of the lamp unit to the direction which arrow "C" or arrow "D" indicate shown in the figure #6, then insert the lamp unit to the direction which arrow "E" indicates in the figure #6.
- 3) Insert the lamp unit slowly and in a straight line during the lamp replacement in order not to break the lamp. Be careful for any dust goes in. And make sure that lamp unit is completely inserted into the LCD module. You can hear clicking noise when the lamp unit is completely inserted .
- 4) Replace the both of the lamp units in same time.

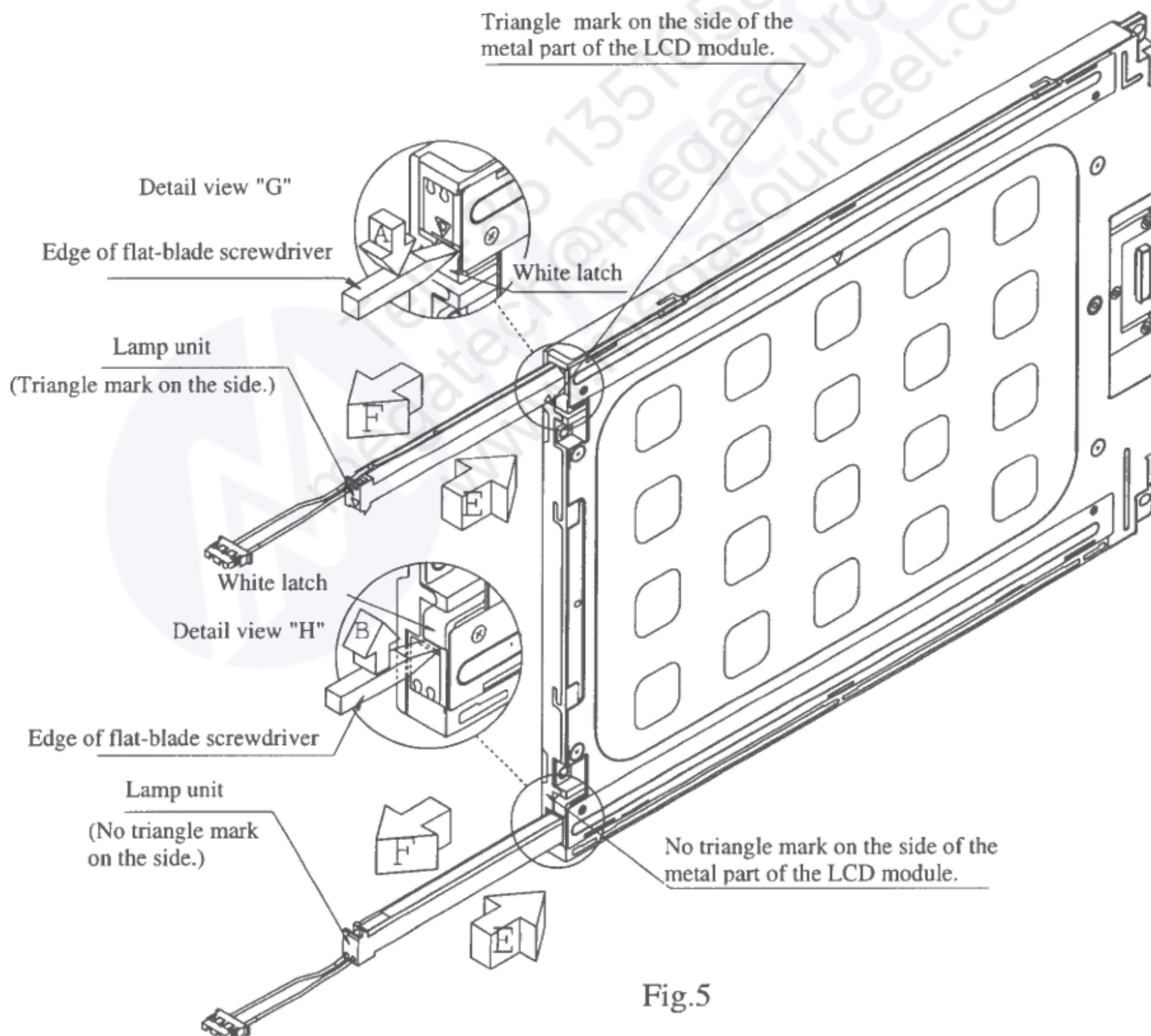

Fig.5

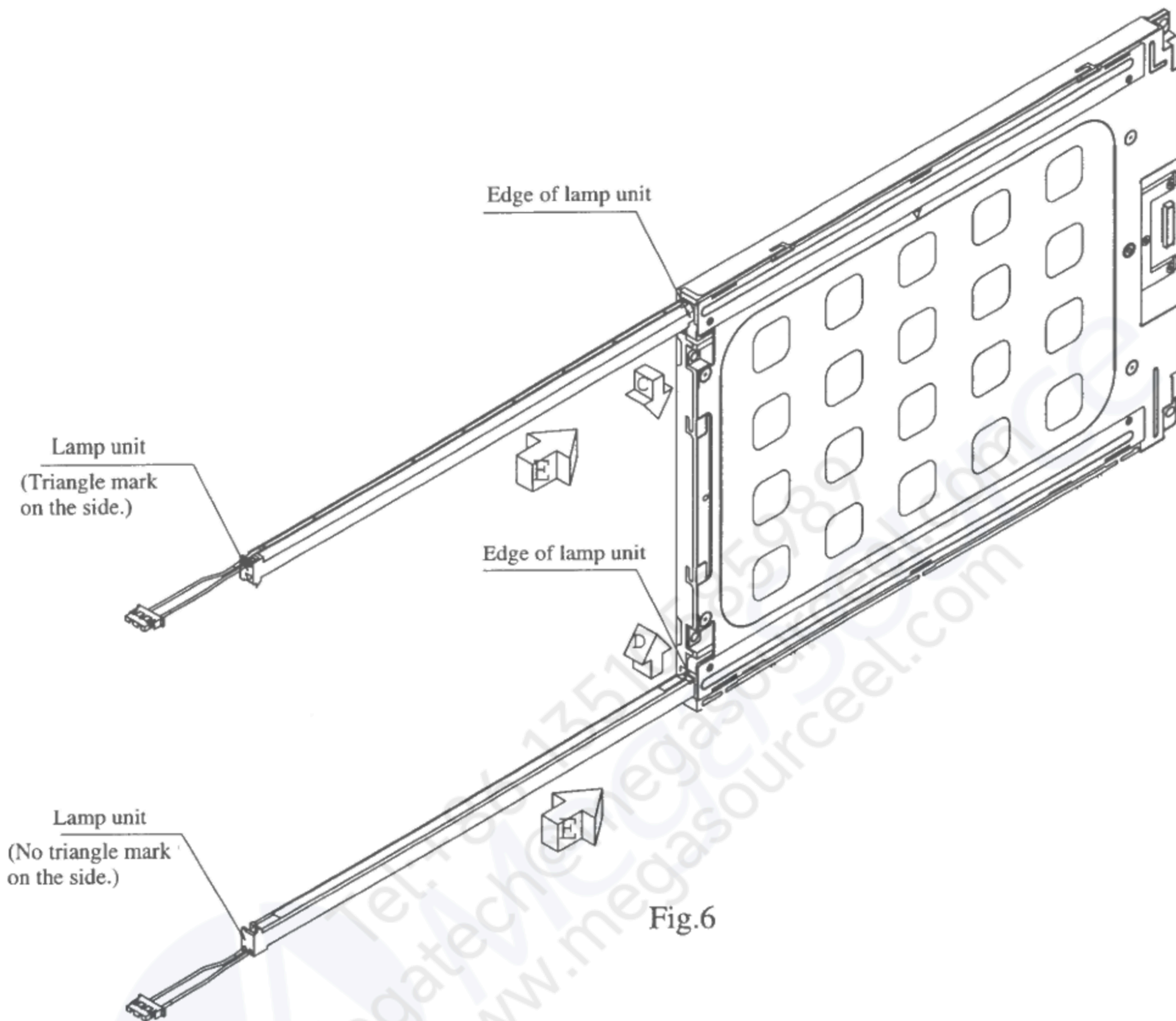

Fig.6

(2) How to replace from backside (See figure #7 & #8)

- 1) Remove 4 screws which hold the holder cover (sheet metal). (Please refer figure #7)
- 2) Slide the holder cover (sheet metal) to the direction which arrow "J" indicates. After checking that the nail is removed from the hub "L", remove 2pcs holder cover (sheet metal).
- 3) Remove the lamp units.
- 4) Out of the 2 pcs of lamp units (2pcs/set), set the replacement lamp which has triangle mark on the side of the lamp unit into the area of the LCD module which also has triangle mark on the rear side of the metal area. And then, set the remaining lamp unit which does not have triangle mark into the area of the LCD module which does not have triangle mark on the side of the metal area (Please refer figure #8).
- 5) Insert the nail of holder cover (sheet metal) into the hub "L" of the LCD module by sliding the 2 pcs of holder cover (sheet metal) slightly to the direction which arrow "K" indicates in the figure #7.
- 6) Tighten 4 screws which hold 2 pcs holder cover (sheet metal) along the thread groove of the prepared hole. Tightening torque is 1.6kgf.cm. If more torque is applied, the thread may be damaged.
- 7) Insert the lamp unit slowly and in a straight line during the lamp replacement in order not to break the lamp. Be careful that dirt or dust does not break into the module. And make sure that lamp unit is completely inserted.
- 8) Replace the both of the lamp units in same time.

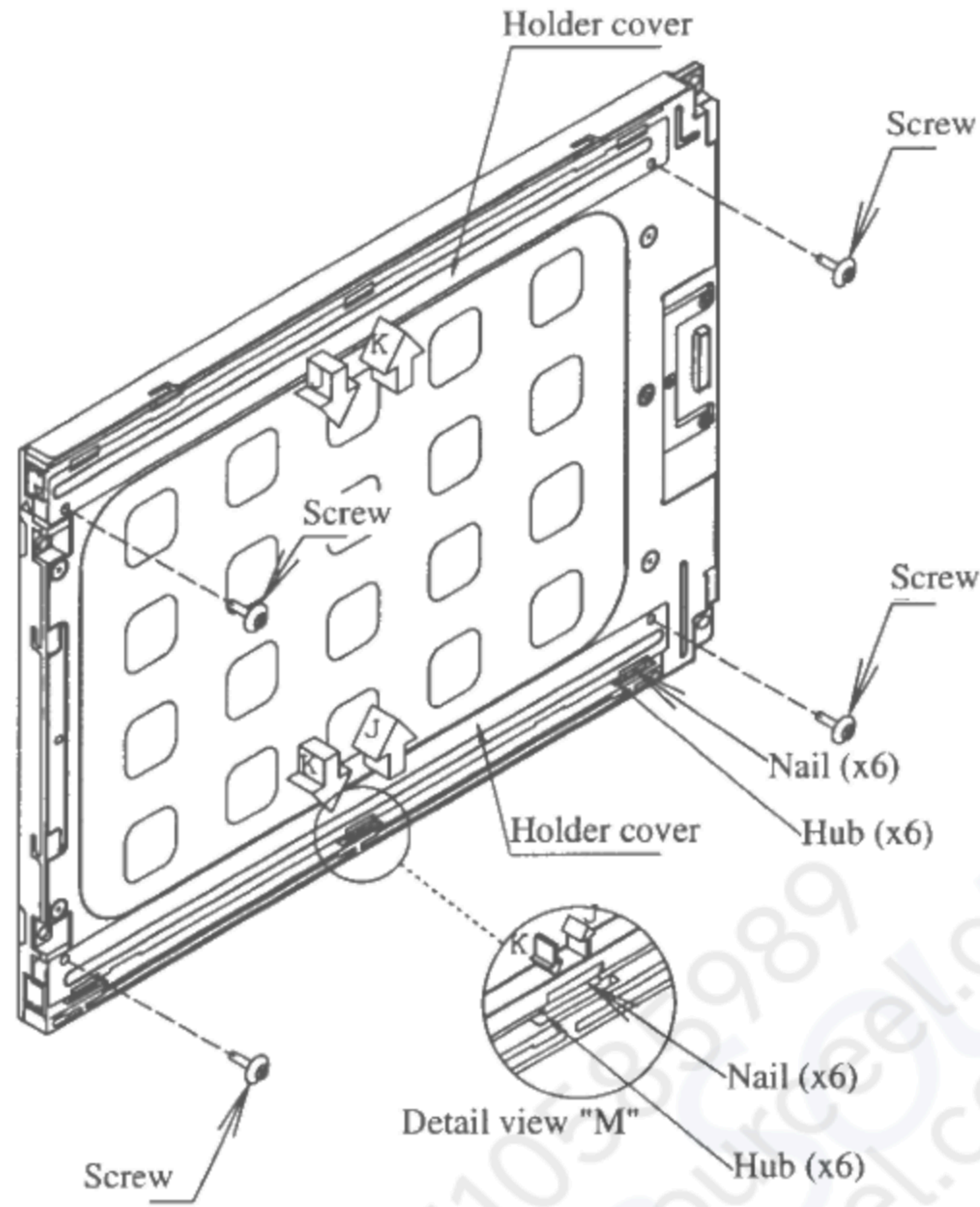

Fig.7

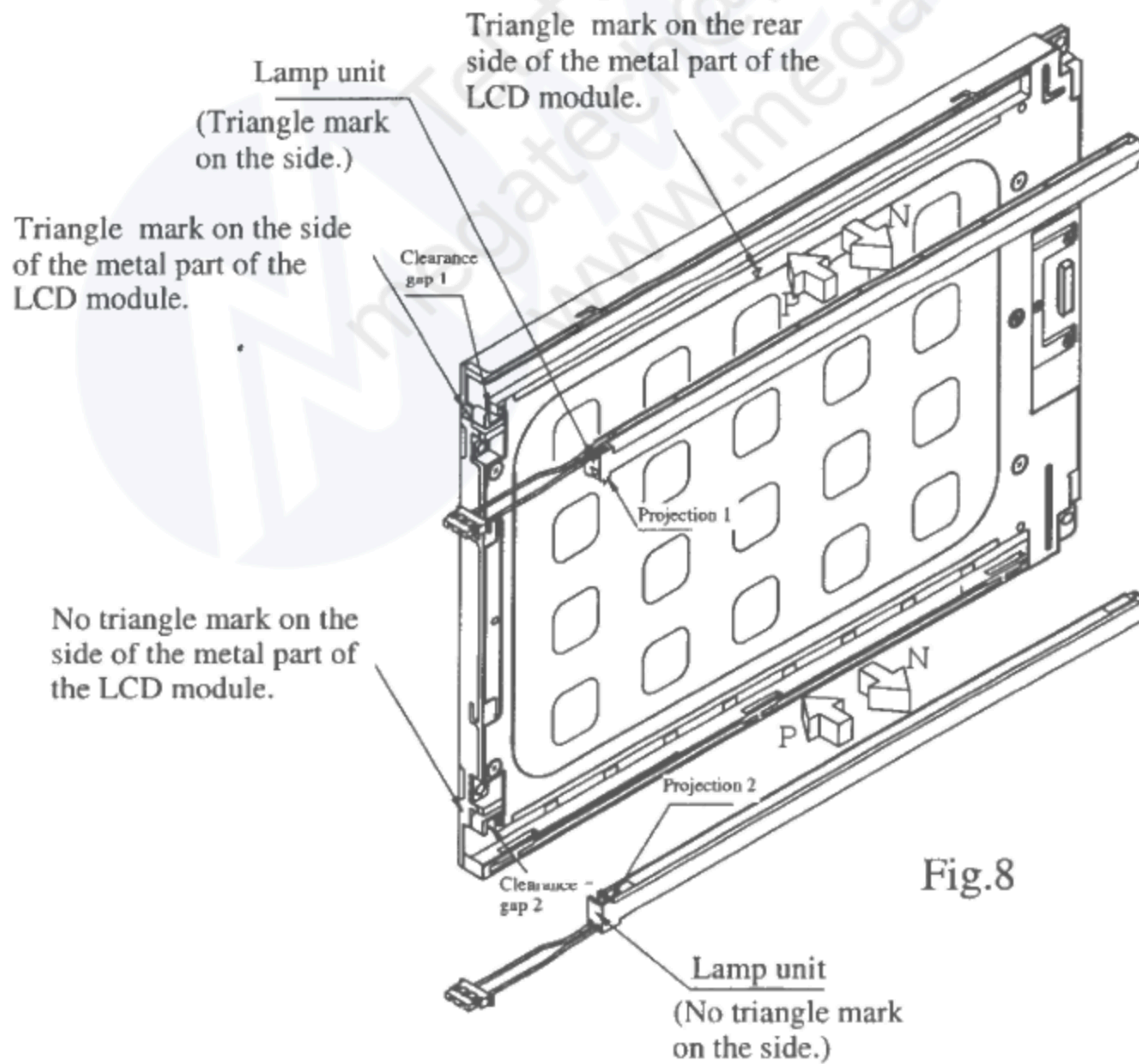

Fig.8

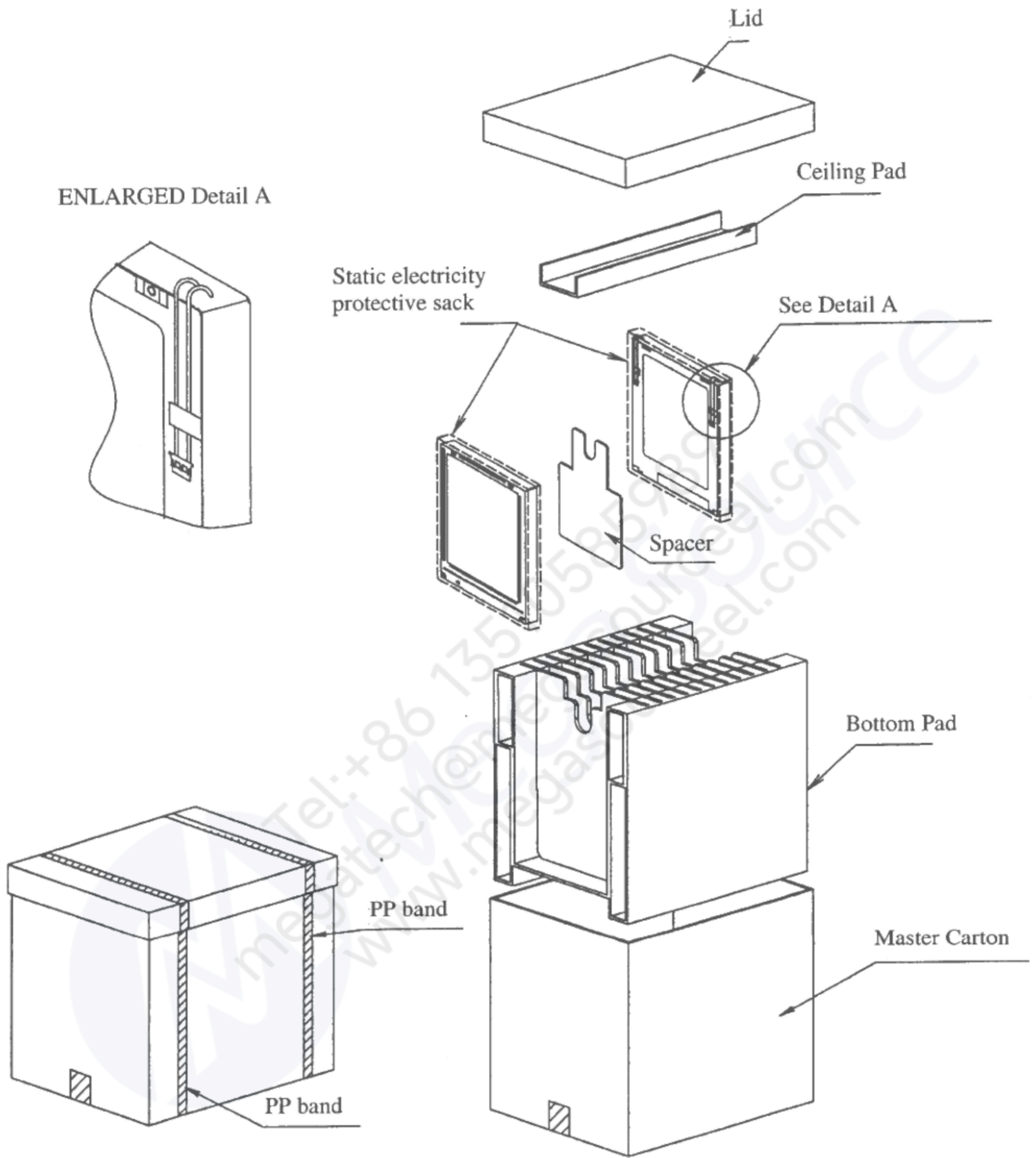

Fig.4 Packing Form

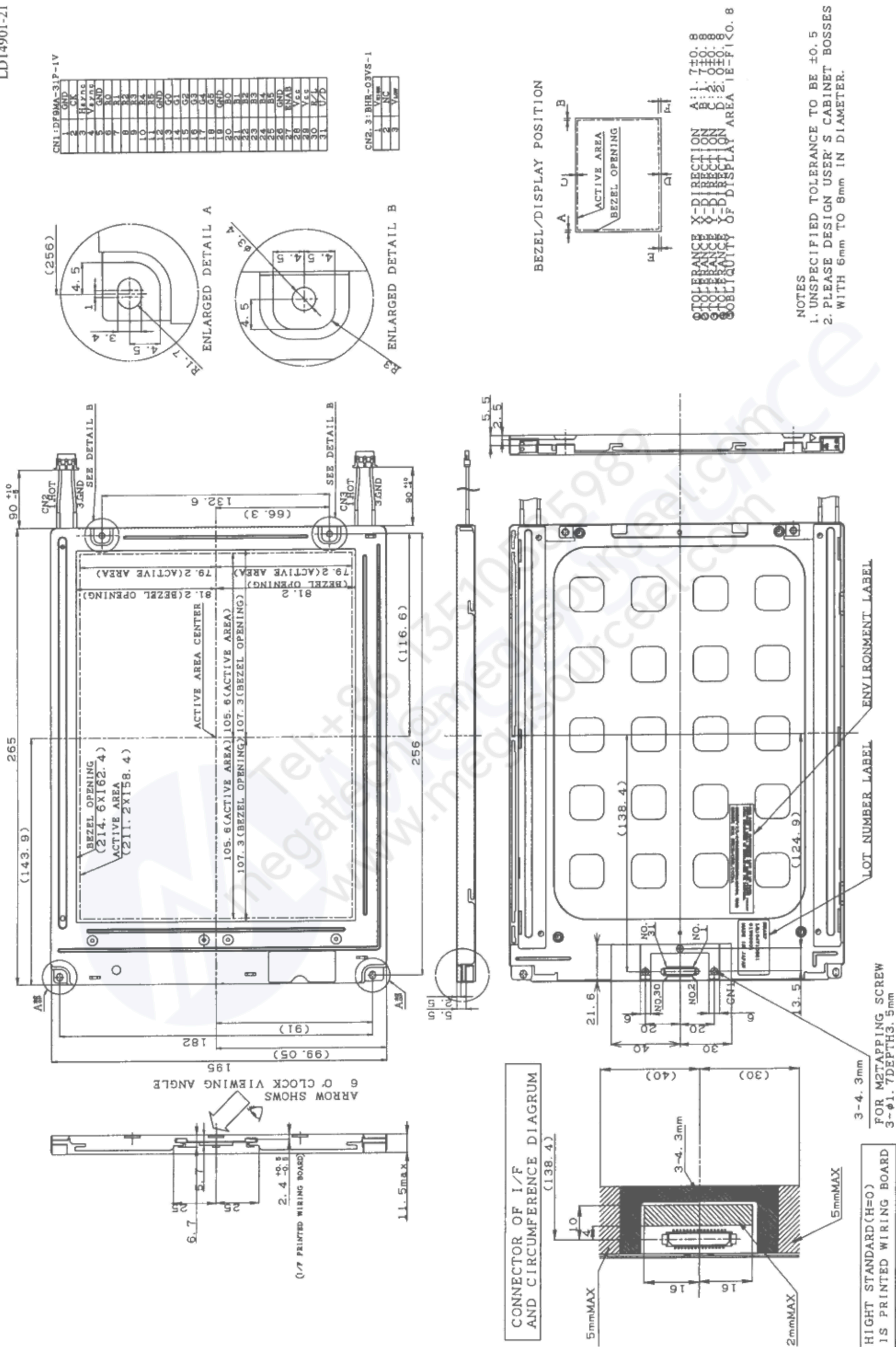

Fig.1 LQ104V1DG21 Outline Dimensions