



**NLT Technologies**

# **TFT COLOR LCD MODULE**

**NL192108AC13-02D**

**29cm (11.6 Type)**

**FHD**

**eDP interface**

**DATA SHEET**

**DOD-PP-2470 (1st edition)**

**This DATA SHEET is updated document from  
PRELIMINARY DOD-PP-2402(4).**

**All information is subject to change without notice.  
Please confirm the sales representative before  
starting to design your system.**

## INTRODUCTION

The Copyright to this document belongs to NLT Technologies, Ltd. (hereinafter called "NLT"). No part of this document will be used, reproduced or copied without prior written consent of NLT.

NLT does and will not assume any liability for infringement of patents, copyrights or other intellectual property rights of any third party arising out of or in connection with application of the products described herein except for that directly attributable to mechanisms and workmanship thereof. No license, express or implied, is granted under any patent, copyright or other intellectual property right of NLT.

Some electronic products would fail or malfunction at a certain rate. In spite of every effort to enhance reliability of products by NLT, the possibility of failures and malfunction might not be avoided entirely. To prevent the risks of damage to death, human bodily injury or other property arising out thereof or in connection therewith, each customer is required to take sufficient measures in its safety designs and plans including, but not limited to, redundant system, fire-containment and anti-failure.

The products are classified into three grades: "**Standard**", "**Special**", and "**Specific**".

Each quality grade is designed for applications described below. Any customer who intends to use a product for application other than that of Standard is required to contact an NLT sales representative in advance.

The **Standard**: Applications as any failure, malfunction or error of the products are free from any damage to death, human bodily injury or other property (Products Safety Issue) and not related the safety of the public (Social Issues), like general electric devices.

Examples: Office equipment, audio and visual equipment, communication equipment, test and measurement equipment, personal electronic equipment, home electronic appliances, car navigation system (with no vehicle control functions), seat entertainment monitor for vehicles and airplanes, fish finder (except marine radar integrated type), PDA, etc.

The **Special**: Applications as any failure, malfunction or error of the products might directly cause any damage to death, human bodily injury or other property (Products Safety Issue) and the safety of the public (Social Issues) and required high level reliability by conventional wisdom.

Examples: Vehicle/train/ship control system, traffic signals system, traffic information control system, air traffic control system, surgery/operation equipment monitor, disaster/crime prevention system, etc.

The **Specific**: Applications as any failure, malfunction or error of the products might severe cause any damage to death, human bodily injury or other property (Products Safety Issue) and the safety of the public (Social Issues) and developed, designed and manufactured in accordance with the standards or quality assurance program designated by the customer who requires extremely high level reliability and quality.

Examples: Aerospace system (except seat entertainment monitor), nuclear control system, life support system, etc.

The quality grade of this product is the "**Standard**" unless otherwise specified in this document.

CONTENTS

**INTRODUCTION ..... 2**

**1. OUTLINE ..... 4**

    1.1 STRUCTURE AND PRINCIPLE ..... 4

    1.2 APPLICATION ..... 4

    1.3 FEATURES ..... 4

**2. GENERAL SPECIFICATIONS ..... 5**

**3. BLOCK DIAGRAM ..... 6**

**4. DETAILED SPECIFICATIONS ..... 7**

    4.1 MECHANICAL SPECIFICATIONS ..... 7

    4.2 ABSOLUTE MAXIMUM RATINGS ..... 7

    4.3 ELECTRICAL CHARACTERISTICS ..... 8

        4.3.1 LCD panel signal processing board ..... 8

        4.3.2 LED driver ..... 8

        4.3.3 Fuse ..... 9

    4.4 POWER SUPPLY VOLTAGE SEQUENCE ..... 10

        4.4.1 LCD panel signal processing board ..... 10

    4.5 CONNECTIONS AND FUNCTIONS FOR INTERFACE PINS ..... 11

        4.5.1 LCD panel signal processing board ..... 11

        4.5.2 Positions of socket ..... 12

    4.6 DISPLAY COLORS AND INPUT DATA SIGNALS ..... 13

    4.7 PIXEL ARRANGEMENT ..... 14

    4.8 eDP SIGNAL TIMING SPECIFICATIONS ..... 15

        4.8.1 Display port main link signal ..... 15

        4.8.2 Display port HPD signal ..... 15

        4.8.3 Display port AUX signal ..... 15

    4.9 INPUT SIGNAL TIMINGS ..... 16

        4.9.1 Outline of input signal timings ..... 16

        4.9.2 Timing characteristics ..... 17

        4.9.3 Input signal timing chart ..... 17

    4.10 OPTICS ..... 18

        4.10.1 Optical characteristics ..... 18

        4.10.2 Definition of contrast ratio ..... 19

        4.10.3 Definition of luminance uniformity ..... 19

        4.10.4 Definition of response times ..... 19

        4.10.5 Definition of viewing angles ..... 19

**5. ESTIMATED LUMINANCE LIFETIME ..... 20**

**6. RELIABILITY TESTS ..... 21**

**7. PRECAUTIONS ..... 22**

    7.1 MEANING OF CAUTION SIGNS ..... 22

    7.2 CAUTIONS ..... 22

    7.3 ATTENTIONS ..... 22

        7.3.1 Handling of the product ..... 22

        7.3.2 Environment ..... 23

        7.3.3 Characteristics ..... 23

        7.3.4 Others ..... 23

**8. OUTLINE DRAWINGS ..... 24**

    8.1 FRONT VIEW ..... 24

    8.2 REAR VIEW ..... 25

## 1. OUTLINE

### 1.1 STRUCTURE AND PRINCIPLE

Color LCD module NL192108AC13-02D is composed of the amorphous silicon thin film transistor liquid crystal display (a-Si TFT LCD) panel structure with driver LSIs for driving the TFT (Thin Film Transistor) array and a backlight.

The a-Si TFT LCD panel structure is injected liquid crystal material into a narrow gap between the TFT array glass substrate and a color-filter glass substrate.

Color (Red, Green, Blue) data signals from a host system (e.g. signal generator, etc.) are modulated into best form for active matrix system by a signal processing board, and sent to the driver LSIs which drive the individual TFT arrays.

The TFT array as an electro-optical switch regulates the amount of transmitted light from the backlight assembly, when it is controlled by data signals. Color images are created by regulating the amount of transmitted light through the TFT array of red, green and blue dots.

### 1.2 APPLICATION

- Color monitor system

### 1.3 FEATURES

- Ultra Wide viewing angle
- High contrast
- Wide color gamut
- Wide temperature range
- eDP interface
- 8-bit digital signals for data of RGB
- LED backlight built in LED driver
- Acquisition product for UL60950-1/CSA-C22.2 No.60950-1-03 (File number: E170632)
- Compliant with the European RoHS directive (2011/65/EU)



2. GENERAL SPECIFICATIONS

<i>Display area</i>	256.32 (H) × 144.18 (V) mm
<i>Diagonal size of display</i>	29cm (11.6 inches)
<i>Drive system</i>	a-Si TFT active matrix
<i>Display color</i>	16,777,216 colors
<i>Pixel</i>	1,920 (H) × 1,080 (V) pixels
<i>Pixel arrangement</i>	RGB (Red dot, Green dot, Blue dot) vertical stripe
<i>Dot pitch</i>	0.0445 (H) × 0.1335 (V) mm
<i>Pixel pitch</i>	0.1335 (H) × 0.1335 (V) mm
<i>Module size</i>	276.5 (W) × 165.6 (H) × 6.0 (D) mm (typ.)
<i>Weight</i>	355 g (typ.)
<i>Contrast ratio</i>	1,000:1 (typ.)
<i>Viewing angle</i>	At the contrast ratio ≥10:1 <ul style="list-style-type: none"> <li>• Horizontal: Right side 88° (typ.), Left side 88° (typ.)</li> <li>• Vertical: Up side 88° (typ.), Down side 88° (typ.)</li> </ul>
<i>Designed viewing direction</i>	• Viewing angle with optimum grayscale ( $\gamma \approx 2.2$ ): Normal axis (perpendicular)
<i>Polarizer surface</i>	Antiglare
<i>Polarizer pencil-hardness</i>	2H (min.) [by JIS K5600]
<i>Color gamut</i>	At LCD panel center 70% (typ.) [against NTSC color space]
<i>Response time</i>	$T_{on} + T_{off}$ (10% ← → 90%) 20ms (typ.)
<i>Luminance</i>	At the maximum luminance control 450cd/m <sup>2</sup> (typ.)
<i>Signal system</i>	eDP 2 lanes 2.7Gbps [8-bit digital signals for data of RGB colors, Dot clock (CLK), Data enable (DE)]
<i>Power supply voltage</i>	LCD panel signal processing board: 3.3V LED backlight: 12.0V
<i>Backlight</i>	LED backlight built in LED driver
<i>Power consumption</i>	At the maximum luminance control, Checkered flag pattern 8.5 W (typ.)

☆

☆

3. BLOCK DIAGRAM

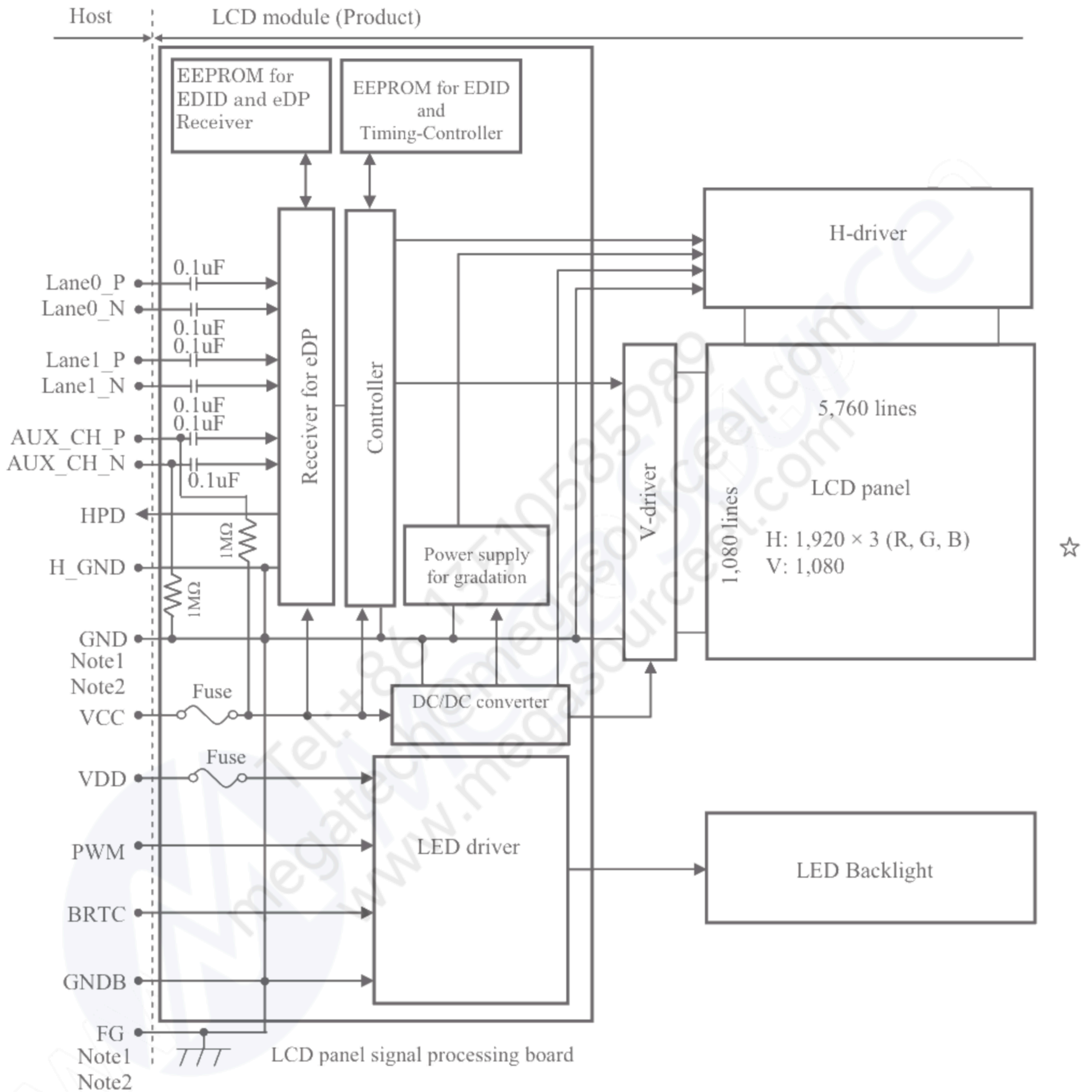

Note1: Relations between H\_GND (High Speed Ground), GND (Signal ground), GNDB (LED driver ground) and FG (Frame ground) in the LCD module are as follows.

H_GND- GND	Connected
H_GND- GNDB	Connected
H_GND- FG	Connected
GND- GNDB	Connected
GND- FG	Connected
GNDB- FG	Connected

Note2: H\_GND, GND, GNDB and FG must be connected to customer equipment's ground, and it is recommended that these grounds to be connected together in customer equipment.

4. DETAILED SPECIFICATIONS

4.1 MECHANICAL SPECIFICATIONS

Parameter	Specification	Unit
Module size	276.5 ± 0.5 (W) × 165.6 ± 0.5 (H) × 6.0 ± 0.5 (D) <span style="float: right;">Note1</span>	mm
Display area	256.32 (H) × 144.18 (V) <span style="float: right;">Note1</span>	mm
Weight	355 (typ.), 390 (max.)	g



Note1: See "8. OUTLINE DRAWINGS".

4.2 ABSOLUTE MAXIMUM RATINGS

Parameter		Symbol	Rating	Unit	Remarks
Power supply voltage	LCD panel signal processing board	VCC	-0.3 to 4.0	V	Ta= 25°C
	LED driver	VDD	-0.3 to 15.0		
Input voltage for signals	Display signals	VD	-0.3 to 4.0	V	
	Function signals for LED driver	PWM	-0.3 to 5.5	V	
		BRTC	-0.3 to 5.5	V	
Storage temperature		Tst	-30 to +80	°C	
Operating temperature	Front surface	TopF	-20 to +70	°C	Note1
	Rear surface	TopR	-20 to +70	°C	Note2
Relative humidity Note3	RH	≤ 95	%	Ta ≤ 40°C	
		≤ 85	%	40°C < Ta ≤ 50°C	
		≤ 55	%	50°C < Ta ≤ 60°C	
		≤ 36	%	60°C < Ta ≤ 70°C	
Absolute humidity Note3	AH	≤ 70 Note4	g/m <sup>3</sup>	Ta > 70°C	

Note1: Measured at LCD panel surface (including self-heat)

Note2: Measured at LCD module's rear shield surface (including self-heat)

Note3: No condensation

Note4: Water amount at Ta= 70°C and RH= 36%

4.3 ELECTRICAL CHARACTERISTICS

4.3.1 LCD panel signal processing board

(Ta= 25°C)

Parameter	Symbol	min.	typ.	max.	Unit	Remarks
Power supply voltage	VCC	3.0	3.3	3.6	V	-
Power supply current	ICC	-	750 Note1	1,200 Note2	mA	at VCC= 3.3V
Permissible ripple voltage	VRP	-	-	100	mVp-p	for VCC Note3, Note4, Note5

☆

Note1: Checkered flag pattern [by IEC 61747-6]

Note2: Pattern for maximum current

Note3: This product works even if the ripple voltage levels are over the permissible values, but there might be noise on the display image.

Note4: The permissible ripple voltage includes spike noise.

Note5: The load variation influence does not include.

4.3.2 LED driver

(Ta= 25°C)

Parameter	Symbol	min.	typ.	max.	Unit	Remarks	
Power supply voltage	VDD	11.4	12.0	12.6	V	Note1	
Power supply current Note2	IDD	-	500	830 Note3	mA	at VDD= 12.0V Note4	
Permissible ripple voltage	VRPD	-	-	100	mVp-p	for VDD Note2, Note5, Note6	
Input voltage for PWM signal	High	VDFH1	2.0	-	5.0	V	-
	Low	VDFL1	0	-	0.8	V	
Input voltage for BRTC signal	High	VDFH2	2.0	-	5.0	V	-
	Low	VDFL2	0	-	0.8	V	
PWM frequency	f <sub>PWM</sub>	200	-	1k	Hz	Note7, Note8	
PWM duty ratio	DR <sub>PWM</sub>	1	-	100	%	Note9, Note10	
PWM pulse width	tPWH	50	-	-	µs		

☆

☆

☆

☆

Note1: When designing of the power supply, take the measures for the prevention of surge voltage.

Note2: The power supply lines (VDD and GND) may have ripple voltage during luminance control of LED. There is the possibility that the ripple voltage produces acoustic noise and signal wave noise in audio circuit and so on.

Note3: This value excludes peak current such as overshoot current.

Note4: At the maximum luminance control

Note5: This product works even if the ripple voltage levels are over the permissible values, but there might be noise on the display image.

Note6: The permissible ripple voltage includes spike noise.

Note7: A recommended f<sub>PWM</sub> value is as follows.

$$f_{PWM} = \frac{2n - 1}{4} \times fv$$

(n = integer, fv = frame frequency of LCD module)

Note8: Depending on the frequency used, some noise may appear on the screen, please conduct a thorough evaluation.

Note9: While the BRTC signal is high, do not set the tPWH (PWM pulse width) is less than minimum value. It may cause abnormal working of the backlight. In this case, turn the backlight off and then on again by BRTC signal.

Note10: Regardless of the PWM frequency, both PWM duty ratio and PWM pulse width must be always more than the minimum values.

4.3.3 Fuse

Parameter	Fuse		Rating	Fusing current	Remarks
	Type	Supplier			
VCC	FHC16322AD	KAMAYA ELECTRIC CO., LTD	3.15A	7.88A	Note1
			24V		
VDD	FCC16162AB	KAMAYA ELECTRIC CO., LTD	1.6A	3.2A	
			36V		

Note1: The power supply's rated current must be more than the fusing current. If it is less than the fusing current, the fuse may not blow in a short time, and then nasty smell, smoke and so on may occur.



4.4 POWER SUPPLY VOLTAGE SEQUENCE

4.4.1 LCD panel signal processing board

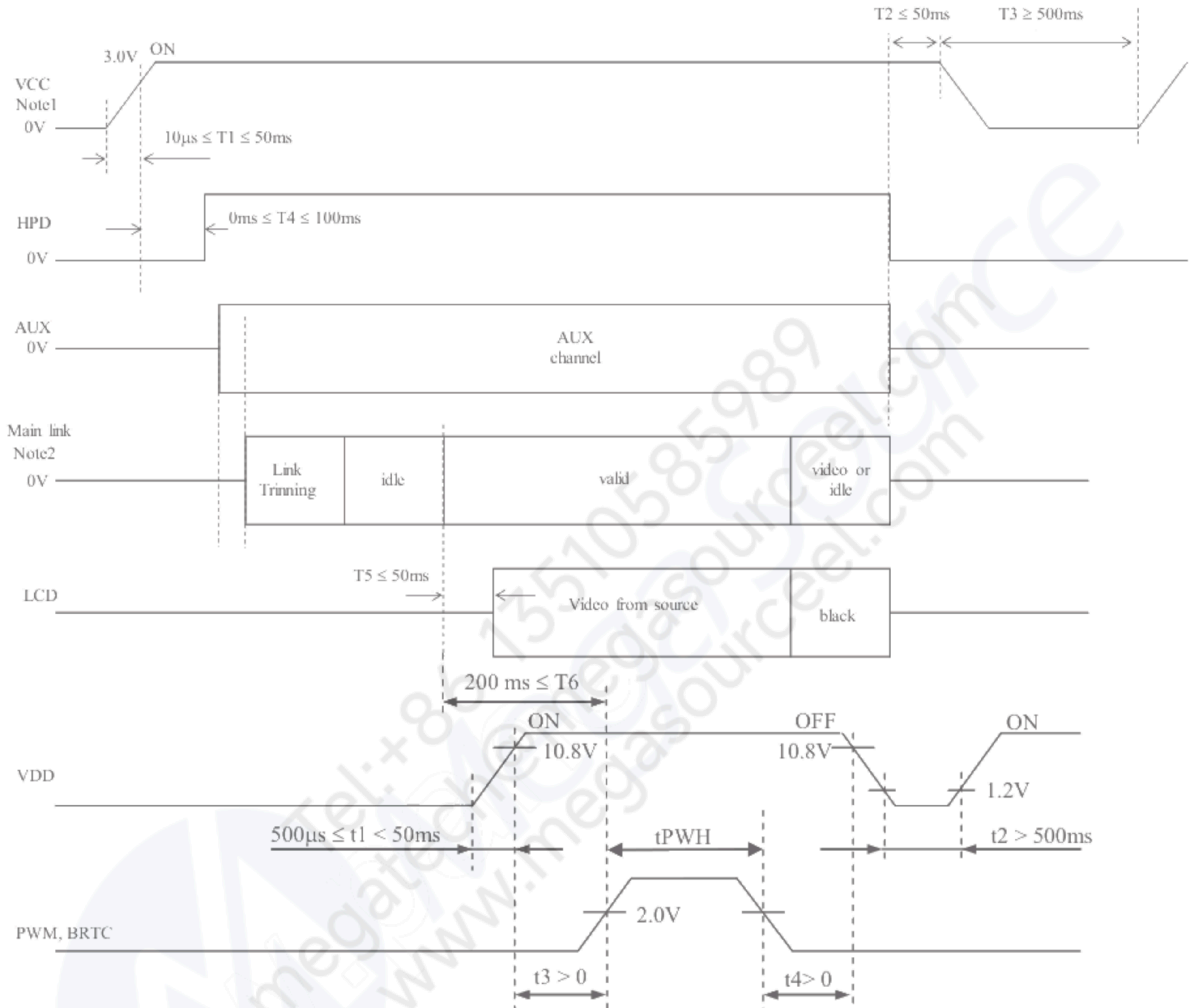

Note1: If there is a voltage variation (voltage drop) at the rising edge of VCC below 3.0V, there is a possibility that a product does not work due to a protection circuit.

Note2: Display signals (Lane0\_P/N, Lane1\_P/N) and function signals (AUX\_CH\_P/N, HPD) must be set to Low or High-impedance, except the VCC ON period (See above sequence diagram), in order to avoid the circuitry damage.

Note3: Depending on the setting of luminance control, it may cause display's flickering during the Power-On time.

4.5 CONNECTIONS AND FUNCTIONS FOR INTERFACE PINS

4.5.1 LCD panel signal processing board

CN1 socket (LCD module side): 20455-040E (IPEX)  
 Adaptable plug: 20453-240T-11 (IPEX, Plug Set)  
 20454-240T (IPEX, HOUSING) or equivalent

Pin	Signal Name	Description	Remarks
1	N.C.	Keep this pin Open.	-
2	N.C.		
3	N.C.		
4	N.C.		
5	N.C.		
6	N.C.		
7	N.C.		
8	H_GND	High Speed Ground	Note1
9	Lane1_N	Complement Signal Link Lane 1	-
10	Lane1_P	True Signal Link Lane 1	-
11	H_GND	High Speed Ground	Note1
12	Lane0_N	Complement Signal Link Lane 0	-
13	Lane0_P	True Signal Link Lane 0	-
14	H_GND	High Speed Ground	Note1
15	AUX_CH_P	True Signal Auxiliary Channel	-
16	AUX_CH_N	Complement Signal Auxiliary Channel	-
17	H_GND	High Speed Ground	Note1
18	VCC	Power supply for LCD panel signal processing board	Note1
19	VCC		
20	VCC		
21	VCC		
22	RSVD	Keep this pin Open.	-
23	GND	Ground	Note1
24	GND		
25	GND		
26	GND		
27	HPD	HPD Signal Pin	-
28	GNDB	LED driver ground	Note1
29	GNDB		
30	GNDB		
31	GNDB		
32	BRTC	Backlight ON/OFF control High or Open: ON Low: OFF	-
33	PWM	PWM signal input for dimming (Luminance control)	-
34	N.C.	Keep this pin Open.	-
35	N.C.		
36	VDD	Power supply for LED driver	Note1
37	VDD		
38	VDD		
39	VDD		
40	N.C.	Keep this pin Open.	-

Note1: All H\_GND, GND, GNDB, VCC and VDD terminals should be used without any non-connected lines.

4.5.2 Positions of socket

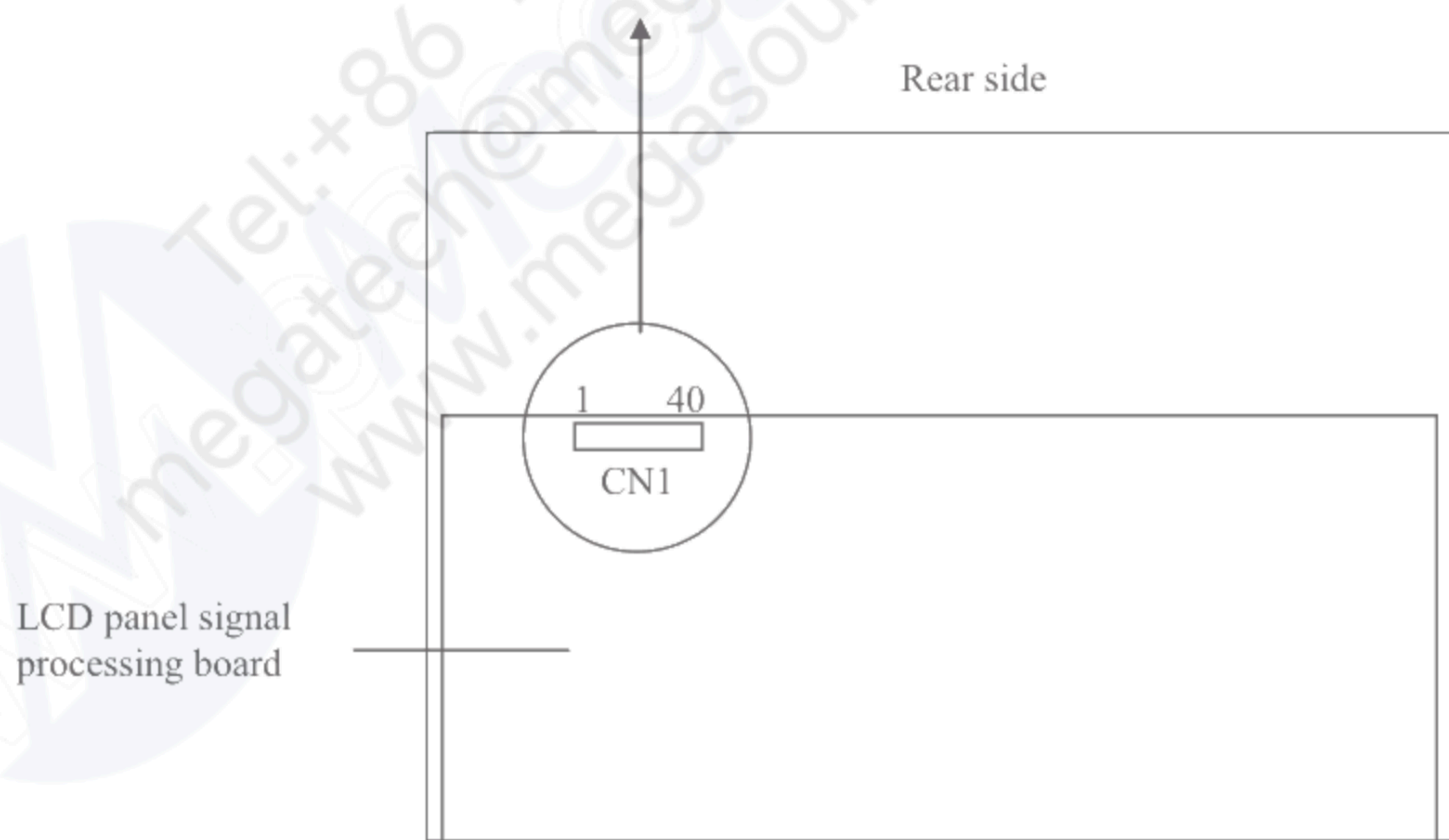
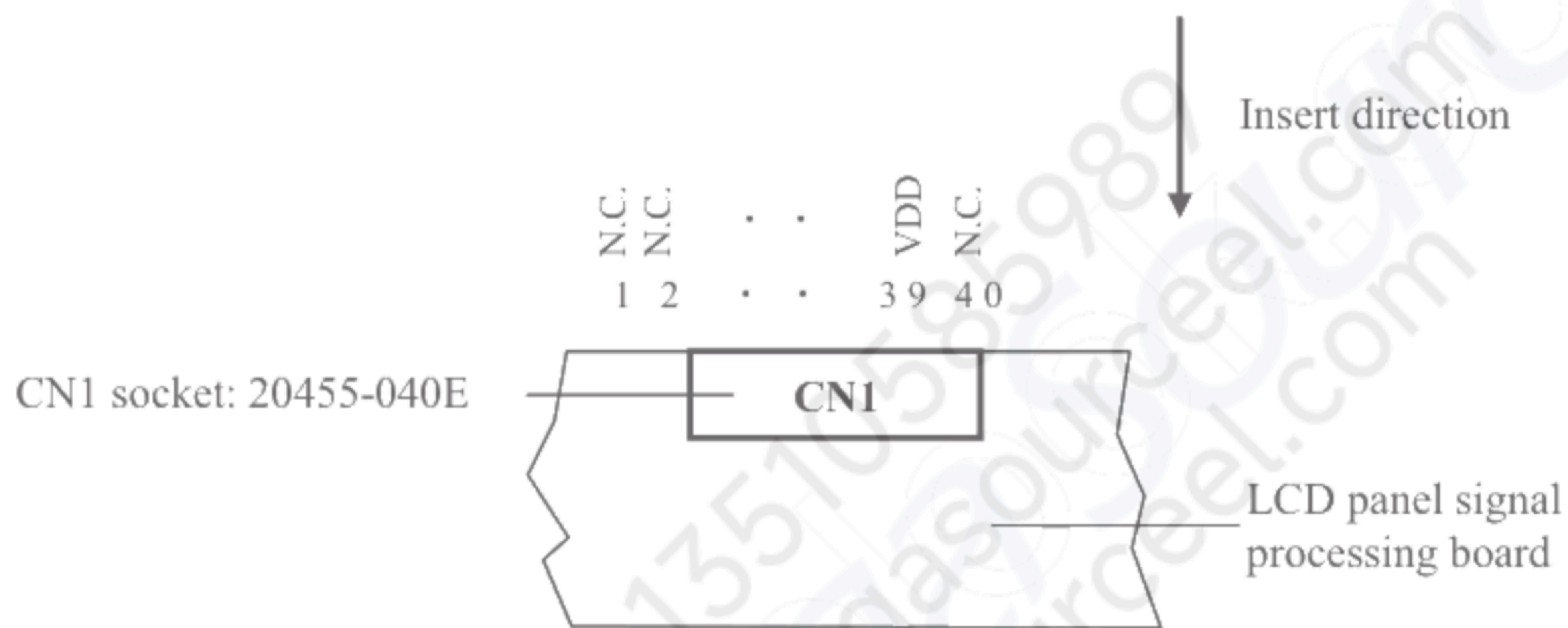
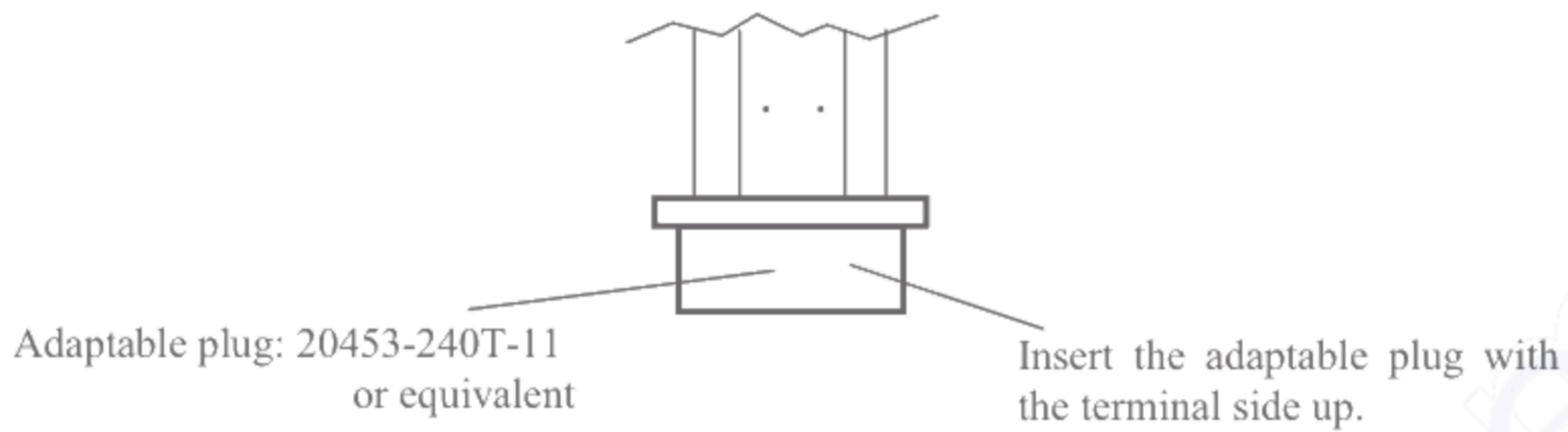

4.6 DISPLAY COLORS AND INPUT DATA SIGNALS

This product can display equivalent of 16,777,216 colors with 256 gray scales.  
 Also the relation between display colors and input data signals is as follows.

Display colors		Input color data																							
		Red								Green								Blue							
		R7	R6	R5	R4	R3	R2	R1	R0	G7	G6	G5	G4	G3	G2	G1	G0	B7	B6	B5	B4	B3	B2	B1	B0
Basic Colors	Black	0	0	0	0	0	0	0	0	0	0	0	0	0	0	0	0	0	0	0	0	0	0	0	0
	Blue	0	0	0	0	0	0	0	0	0	0	0	0	0	0	0	0	1	1	1	1	1	1	1	1
	Red	1	1	1	1	1	1	1	1	0	0	0	0	0	0	0	0	0	0	0	0	0	0	0	0
	Magenta	1	1	1	1	1	1	1	1	0	0	0	0	0	0	0	0	1	1	1	1	1	1	1	1
	Green	0	0	0	0	0	0	0	0	1	1	1	1	1	1	1	1	0	0	0	0	0	0	0	0
	Cyan	0	0	0	0	0	0	0	0	1	1	1	1	1	1	1	1	1	1	1	1	1	1	1	1
	Yellow	1	1	1	1	1	1	1	1	1	1	1	1	1	1	1	1	0	0	0	0	0	0	0	0
	White	1	1	1	1	1	1	1	1	1	1	1	1	1	1	1	1	1	1	1	1	1	1	1	1
Red gray scale	Black	0	0	0	0	0	0	0	0	0	0	0	0	0	0	0	0	0	0	0	0	0	0	0	0
		0	0	0	0	0	0	0	1	0	0	0	0	0	0	0	0	0	0	0	0	0	0	0	0
	dark	0	0	0	0	0	0	1	0	0	0	0	0	0	0	0	0	0	0	0	0	0	0	0	0
	↑				:	:						:	:						:	:					
	↓				:	:						:	:						:	:					
	bright	1	1	1	1	1	1	0	1	0	0	0	0	0	0	0	0	0	0	0	0	0	0	0	0
Red	1	1	1	1	1	1	1	0	0	0	0	0	0	0	0	0	0	0	0	0	0	0	0	0	
Red	1	1	1	1	1	1	1	1	0	0	0	0	0	0	0	0	0	0	0	0	0	0	0	0	
Green gray scale	Black	0	0	0	0	0	0	0	0	0	0	0	0	0	0	0	0	0	0	0	0	0	0	0	0
		0	0	0	0	0	0	0	0	0	0	0	0	0	0	0	1	0	0	0	0	0	0	0	0
	dark	0	0	0	0	0	0	0	0	0	0	0	0	0	0	1	0	0	0	0	0	0	0	0	0
	↑				:	:						:	:						:	:					
	↓				:	:						:	:						:	:					
	bright	0	0	0	0	0	0	0	0	1	1	1	1	1	1	0	1	0	0	0	0	0	0	0	0
Green	0	0	0	0	0	0	0	0	1	1	1	1	1	1	1	0	0	0	0	0	0	0	0	0	
Green	0	0	0	0	0	0	0	0	1	1	1	1	1	1	1	1	0	0	0	0	0	0	0	0	
Blue gray scale	Black	0	0	0	0	0	0	0	0	0	0	0	0	0	0	0	0	0	0	0	0	0	0	0	0
		0	0	0	0	0	0	0	0	0	0	0	0	0	0	0	0	0	0	0	0	0	0	0	1
	dark	0	0	0	0	0	0	0	0	0	0	0	0	0	0	0	0	0	0	0	0	0	0	1	0
	↑				:	:						:	:						:	:					
	↓				:	:						:	:						:	:					
	bright	0	0	0	0	0	0	0	0	0	0	0	0	0	0	0	0	1	1	1	1	1	1	0	1
Blue	0	0	0	0	0	0	0	0	0	0	0	0	0	0	0	0	1	1	1	1	1	1	1	0	
Blue	0	0	0	0	0	0	0	0	0	0	0	0	0	0	0	0	1	1	1	1	1	1	1	1	

4.7 PIXEL ARRANGEMENT

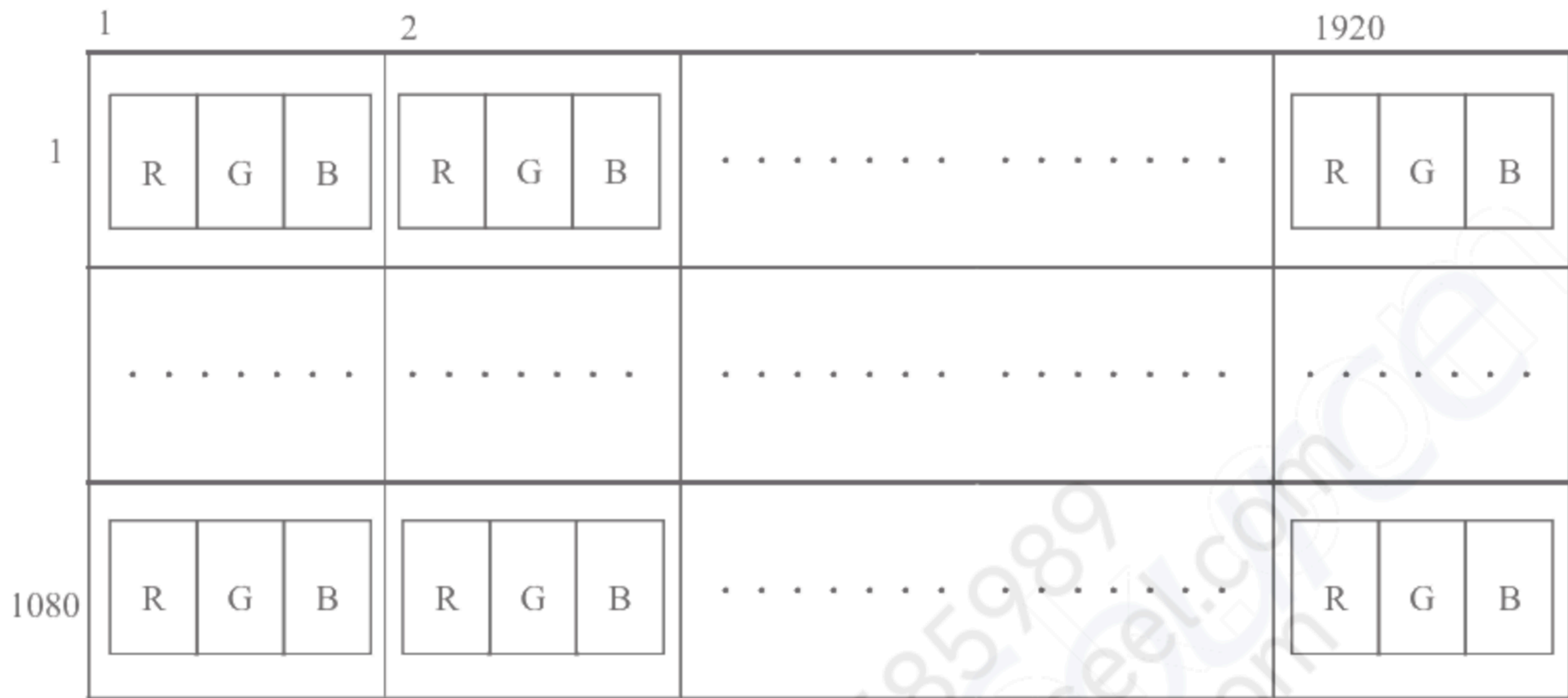

4.8 eDP SIGNAL TIMING SPECIFICATIONS

4.8.1 Display port main link signal

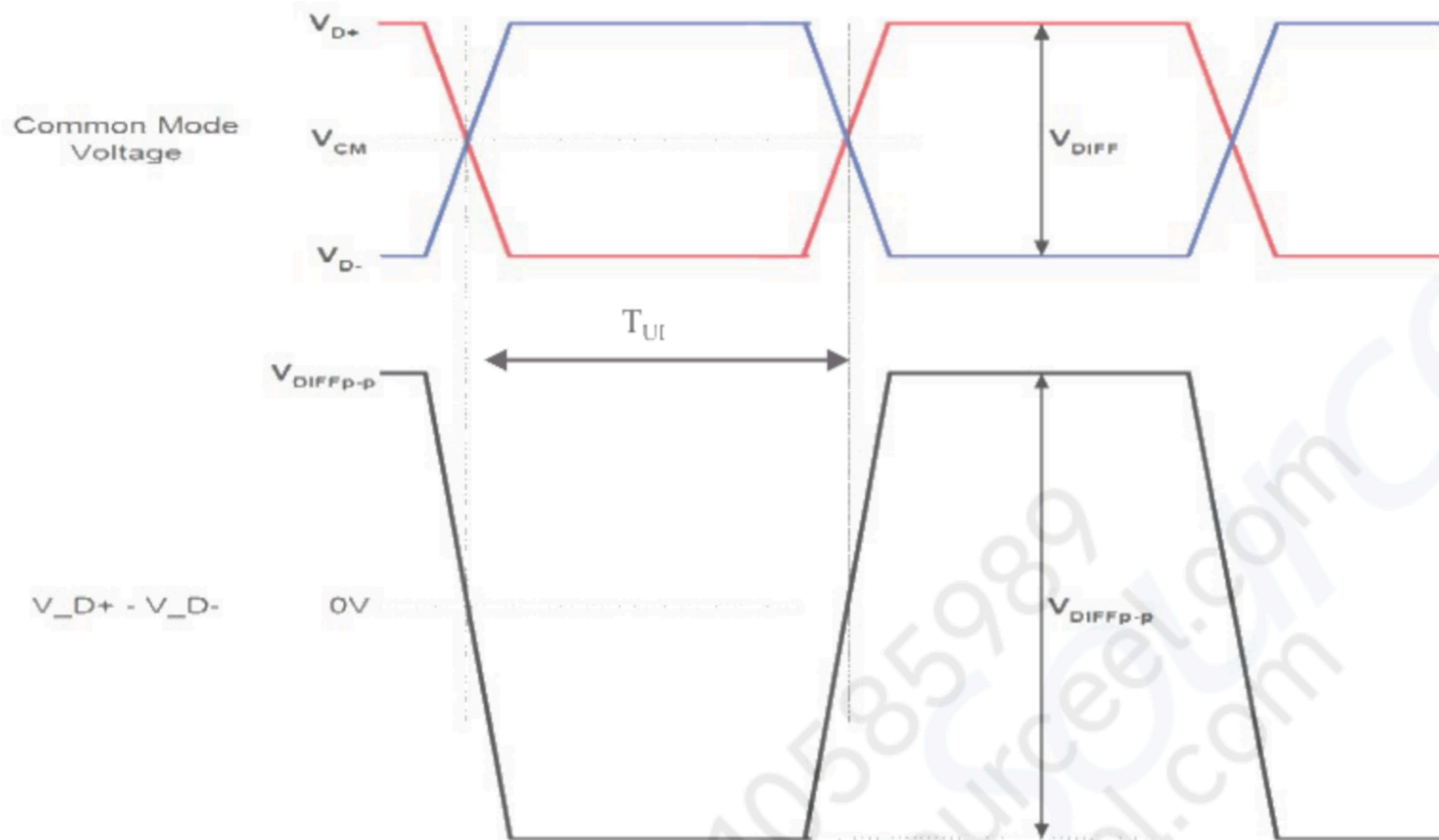

Parameter	Symbol	min.	typ.	max.	Unit	Remarks
Differential peak-to-peak input voltage	VDIFFp-p	120	-	1,380	mV	-
Rx input DC common mode voltage	VCM	0	-	2.0	V	-
Jitter tracking bandwidth	-	20	-	-	MHz	-
Link clock down spreading	-	0	-	0.5	%	-

☆  
☆  
☆

4.8.2 Display port HPD signal

Description	Symbol	min.	typ.	max.	Unit	Remarks
Hot Plug detect	HPD	2.4	-	3.6	V	-

☆

4.8.3 Display port AUX signal

Description	Symbol	min.	typ.	max.	Unit	Remarks
AUX differential peak-to-peak voltage when driving	-	0.39	-	1.38	V	-
AUX differential peak-to-peak voltage when receiving	-	0.32	-	1.36	V	-
AUX DC common-mode voltage	-	0	-	2.0	V	-
AUX CH termination DC resistance	-	-	100	-	$\Omega$	-
Unit interval	-	0.4	0.5	0.6	$\mu$ s	-
Cycle-to-cycle jitter time when driving	-	-	-	0.04	UI	-
Cycle-to-cycle jitter time when receiving	-	-	-	0.05	UI	-

☆  
☆

4.9 INPUT SIGNAL TIMINGS

4.9.1 Outline of input signal timings

- Horizontal signal

Note1

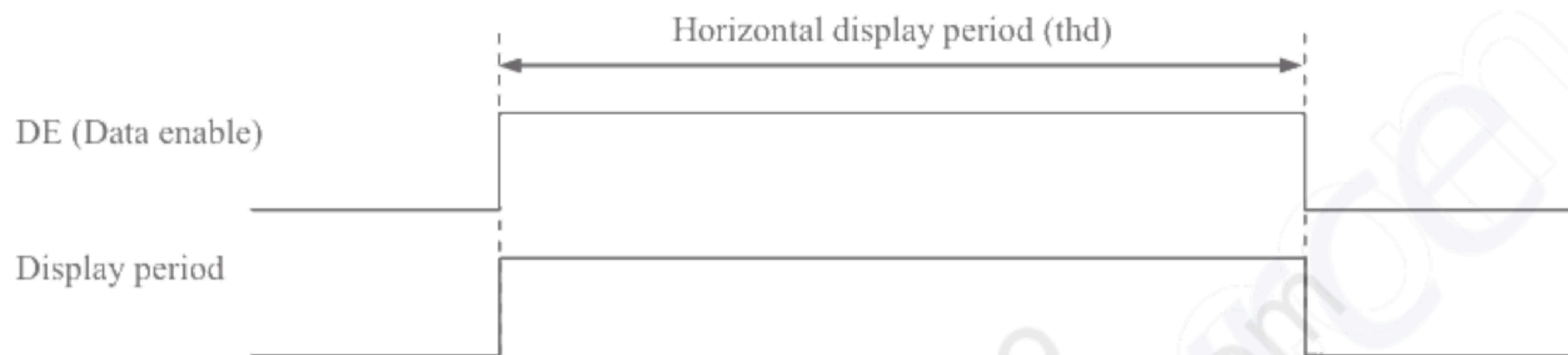

- Vertical signal

Note1

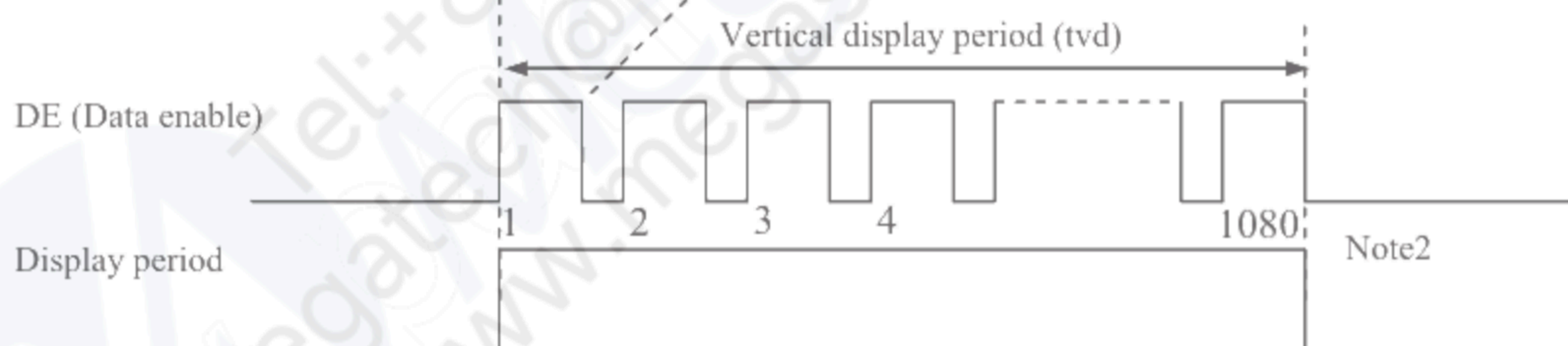

Note1: This diagram indicates virtual signal for set up to timing.

Note2: See "4.9.3 Input signal timing chart" for the pulse number.

4.9.2 Timing characteristics

(Note1)

Parameter		Symbol	min.	typ.	max.	Unit	Remarks	
CLK	Frequency	1/tc	132.0	138.5	145.0	MHz	7.220ns (typ.)	
	Duty ratio	-				-	-	
	Rise time, Fall time	-				ns	-	
DE	Horizontal	Cycle	th	-	15.02	-	$\mu$ s	66.59kHz (typ.)
		Display period	thd	1,920			CLK	
	Vertical (One frame)	Cycle	tv	-	16.7	-	ms	59.88Hz (typ.)
				-	1,112	-	H	
		Display period	tvd	1,080			H	

Note1: Definition of parameters is as follows.  
 tc= 1CLK, th= 1H

4.9.3 Input signal timing chart

Horizontal timing

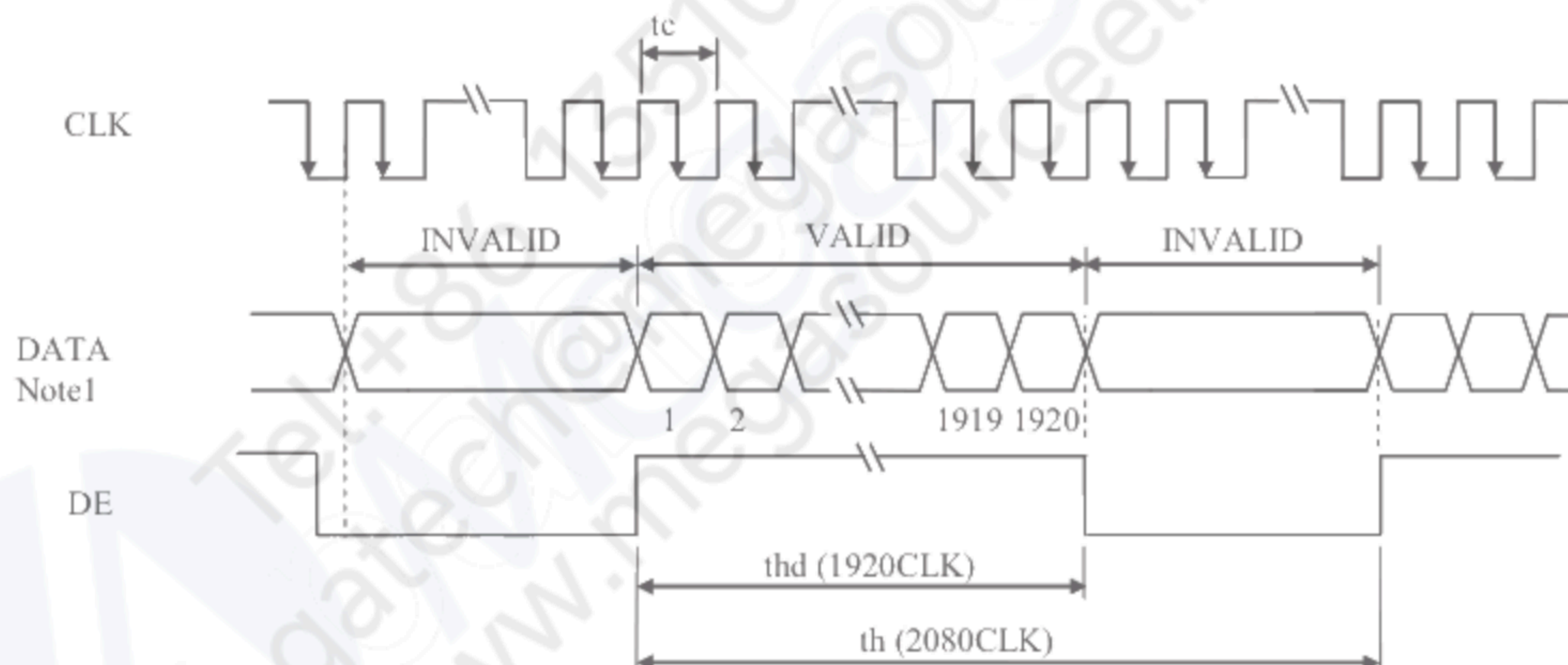

Vertical timing

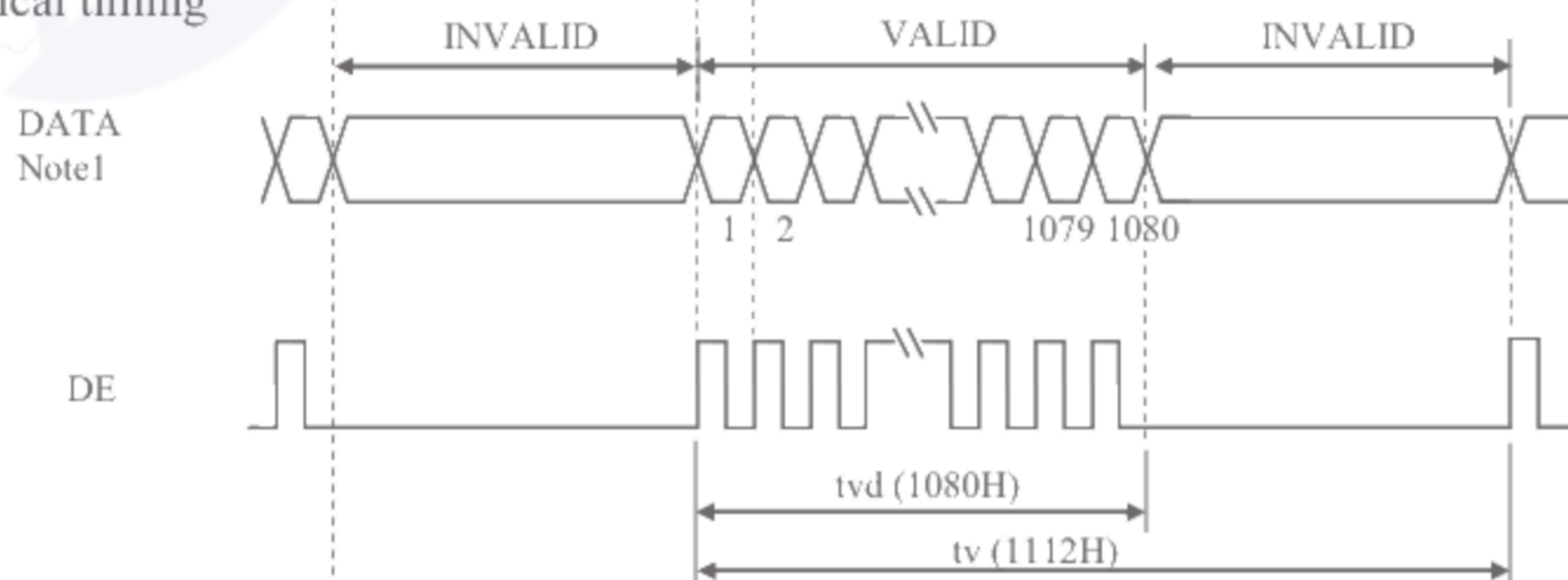

Note1: DATA = R0-R7, G0-G7, B0-B7

4.10 OPTICS

4.10.1 Optical characteristics

(Note1, Note2)

Parameter	Condition	Symbol	min.	typ.	max.	Unit	Measuring instrument	Remarks	
Luminance	White at center $\theta_R=0^\circ, \theta_L=0^\circ, \theta_U=0^\circ, \theta_D=0^\circ$	L	300	450	-	cd/m <sup>2</sup>	BM-5A or equivalent	-	
Contrast ratio	White/Black at center $\theta_R=0^\circ, \theta_L=0^\circ, \theta_U=0^\circ, \theta_D=0^\circ$	CR	600	1,000	-	-	BM-5A or equivalent	Note3	
Luminance uniformity	White $\theta_R=0^\circ, \theta_L=0^\circ, \theta_U=0^\circ, \theta_D=0^\circ$	LU	-	1.25	1.4	-	BM-5A	Note4	
Chromaticity	White	x coordinate	Wx	0.263	0.313	0.363	-	SR-3 or equivalent	Note5
		y coordinate	Wy	0.279	0.329	0.379	-		
	Red	x coordinate	Rx	-	0.635	-	-		
		y coordinate	Ry	-	0.340	-	-		
	Green	x coordinate	Gx	-	0.315	-	-		
		y coordinate	Gy	-	0.615	-	-		
Blue	x coordinate	Bx	-	0.150	-	-			
	y coordinate	By	-	0.055	-	-			
Color gamut	$\theta_R=0^\circ, \theta_L=0^\circ, \theta_U=0^\circ, \theta_D=0^\circ$ at center, against NTSC color space	C	65	70	-	%			
Response time	Black to White	Ton	-	10	20	ms	BM-5A or equivalent	Note6	
	White to Black	Toff	-	10	20	ms		Note7	
Viewing angle	Right	$\theta_U=0^\circ, \theta_D=0^\circ, CR \geq 10$	$\theta_R$	70	88	-	EZ Contrast	Note8	
	Left	$\theta_U=0^\circ, \theta_D=0^\circ, CR \geq 10$	$\theta_L$	70	88	-			
	Up	$\theta_R=0^\circ, \theta_L=0^\circ, CR \geq 10$	$\theta_U$	70	88	-			
	Down	$\theta_R=0^\circ, \theta_L=0^\circ, CR \geq 10$	$\theta_D$	70	88	-			

Note1: These are initial characteristics.

Note2: Measurement conditions are as follows.

Ta= 25°C, VCC= 3.3V, VDD=12.0V, PWM duty ratio: 100%,

Display mode: FHD, Horizontal cycle= 1/66.59kHz, Vertical cycle= 1/59.88Hz,

Optical characteristics are measured at luminance saturation 20minutes after the product works in the dark room. Also measurement methods are as follows.

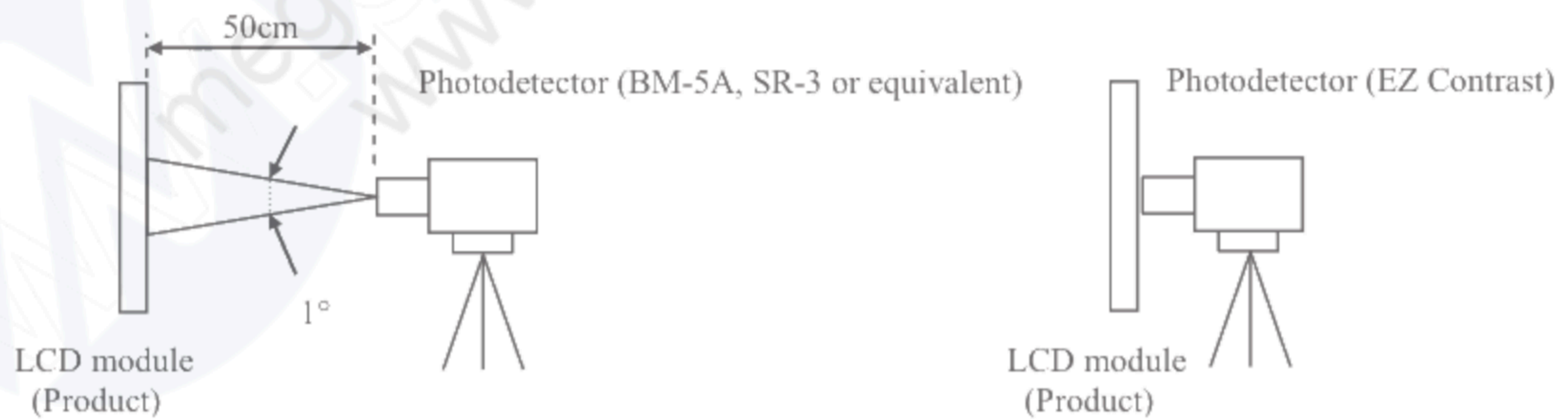

Note3: See "4.10.2 Definition of contrast ratio".

Note4: See "4.10.3 Definition of luminance uniformity".

Note5: These coordinates are found on CIE 1931 chromaticity diagram.

Note6: Product surface temperature: TopF= 31°C

Note7: See "4.10.4 Definition of response times".

Note8: See "4.10.5 Definition of viewing angles".

4.10.2 Definition of contrast ratio

The contrast ratio is calculated by using the following formula.

$$\text{Contrast ratio (CR)} = \frac{\text{Luminance of white screen}}{\text{Luminance of black screen}}$$

4.10.3 Definition of luminance uniformity

The luminance uniformity is calculated by using following formula.

$$\text{Luminance uniformity (LU)} = \frac{\text{Maximum luminance from ① to ⑤}}{\text{Minimum luminance from ① to ⑤}}$$

The luminance is measured at near the 5 points shown below.



4.10.4 Definition of response times

Response time is measured at the time when the luminance changes from "black" to "white", or "white" to "black" on the same screen point, by photo-detector. Ton is the time when the luminance changes from 10% up to 90%. Also Toff is the time when the luminance changes from 90% down to 10% (See the following diagram.).

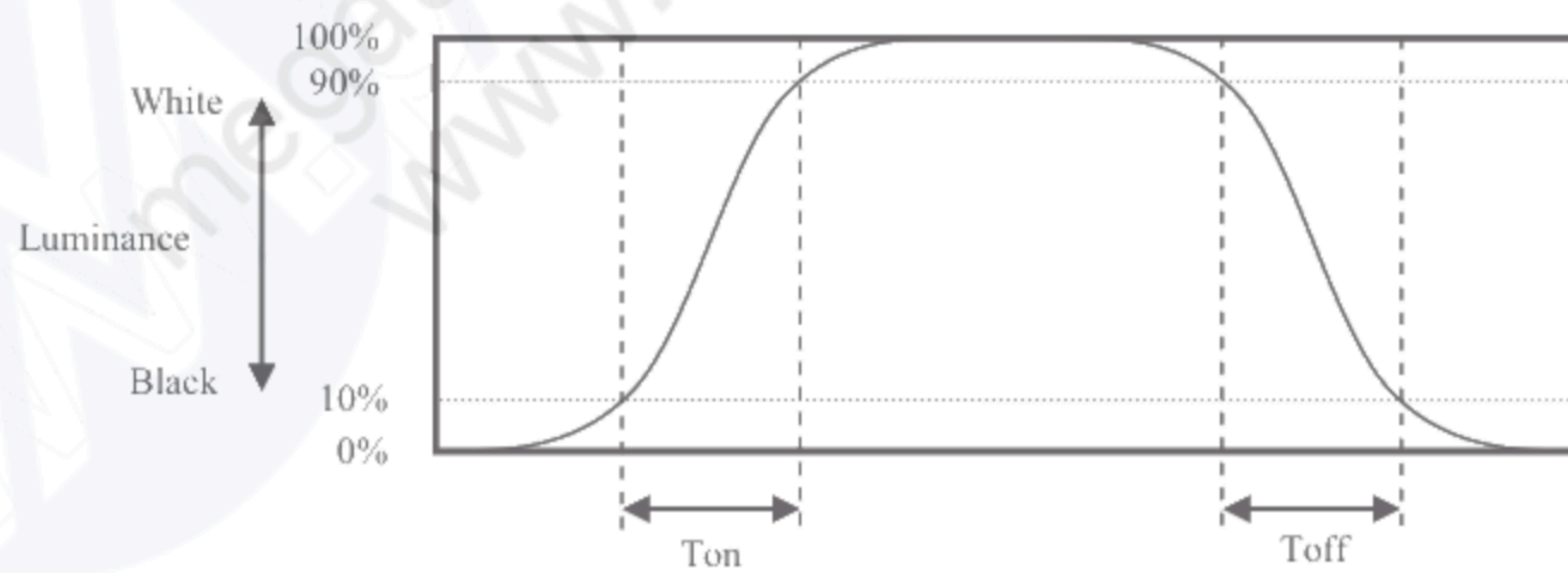

4.10.5 Definition of viewing angles

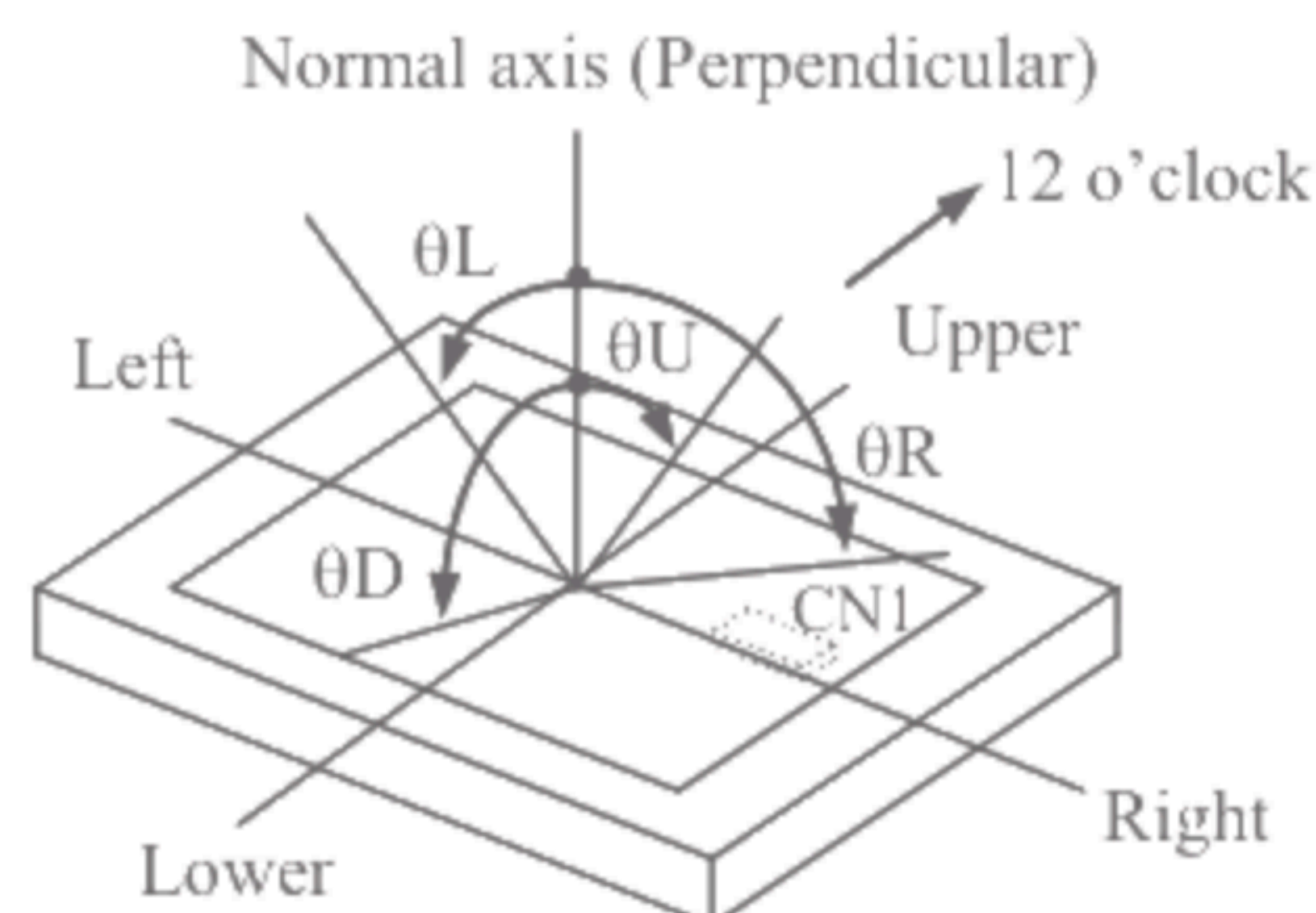

**5. ESTIMATED LUMINANCE LIFETIME**

The luminance lifetime is the time from initial luminance to half-luminance.

**This lifetime is the estimated value, and is not guarantee value.**

Condition		Estimated luminance lifetime (Life time expectancy) Note1, Note2, Note3	Unit
LED elementary substance	25°C (Ambient temperature of the product) Continuous operation, PWM duty ratio:100%	30,000	h
	70°C (Ambient temperature of the product) Continuous operation, PWM duty ratio:100%	10,000	

☆

☆

Note1: Life time expectancy is mean time to half-luminance.

Note2: Estimated luminance lifetime is not the value for LCD module but the value for LED elementary substance.

Note3: By ambient temperature, the lifetime changes particularly. Especially, in case the product works under high temperature environment, the lifetime becomes short.

6. RELIABILITY TESTS

Test item	Condition	Judgment	Note1
High temperature and humidity (Operation)	① +60 ± 2°C, RH= 90%, 240hours ② Display data is white.	No display malfunctions	
High temperature (Operation)	① +70 ± 3°C, 240hours ② Display data is white.		
Heat cycle (Operation)	① -20 ± 3°C...1hour +70 ± 3°C...1hour ② 50cycles, 4hours/cycle ③ Display data is white		
Thermal shock (Non operation)	① -30 ± 3°C...30minutes +80 ± 3°C...30minutes ② 100cycles, 1hour/cycle ③ Temperature transition time is within 5 minutes.		
ESD (Operation)	① 150pF, 150Ω, ±10kV ② 9 places on a panel surface Note2 ③ 10 times each point at 1 sec interval		
Dust (Operation)	① Sample dust: No. 15 (by JIS-Z8901) ② 15 seconds stir ③ 8 times repeat at 1 hour interval		
Vibration (Non operation)	① 5 to 100Hz, 19.6m/s <sup>2</sup> ② 1 minute/cycle ③ X, Y, Z directions ④ 120 times each direction		
Mechanical shock (Non operation)	① 539m/ s <sup>2</sup> , 11ms ② ±X, ±Y, ±Z directions ③ 5 times each direction		

Note1: Display and appearance are checked under environmental conditions equivalent to the inspection conditions of defect criteria.

Note2: See the following figure for discharge points.

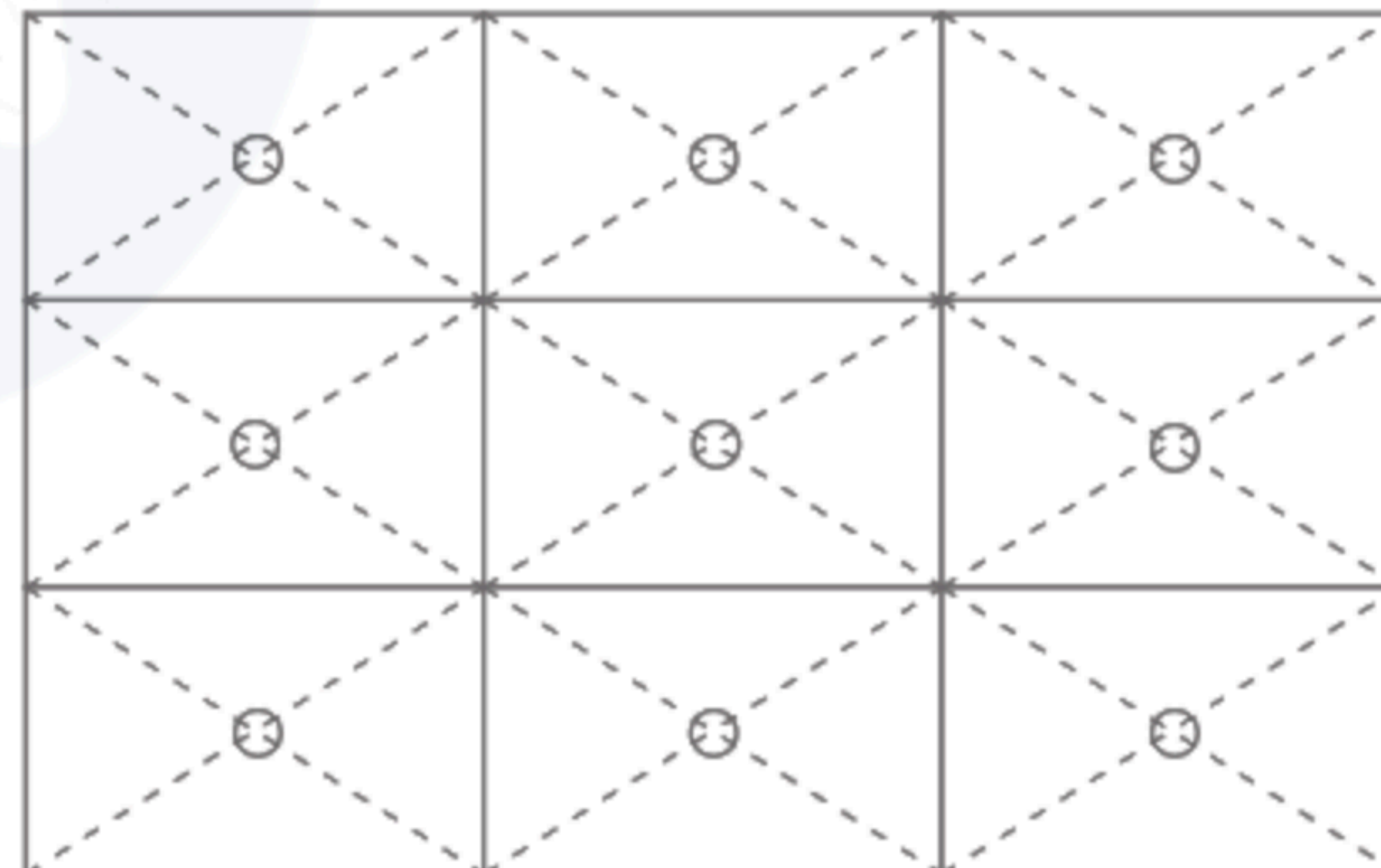

7. PRECAUTIONS

7.1 MEANING OF CAUTION SIGNS

The following caution signs have very important meaning. **Be sure to read "7.2 CAUTIONS" and "7.3 ATTENTIONS"!**

	This sign has the meaning that a customer will be injured or the product will sustain damage if the customer practices wrong operations.
---	--

	This sign has the meaning that a customer will be injured if the customer practices wrong operations.
---	---

7.2 CAUTIONS

	<p><b>* Do not shock and press the LCD panel and the backlight! There is a danger of breaking, because they are made of glass. (Shock: Equal to or no greater than 539m/s<sup>2</sup> and equal to or no greater than 11ms, Pressure: Equal to or no greater than 19.6 N (φ16mm jig))</b></p>
---	---

7.3 ATTENTIONS 

7.3.1 Handling of the product

- ① Take hold of both ends without touching the circuit board when the product (LCD module) is picked up from inner packing box to avoid broken down or misadjustment, because of stress to mounting parts on the circuit board.
- ② When the product is put on the table temporarily, display surface must be placed downward.
- ③ When handling the product, take the measures of electrostatic discharge with such as earth band, ionic shower and so on, because the product may be damaged by electrostatic.
- ④ The product must be installed using mounting holes without undue stress such as bends or twist (See outline drawings). And do not add undue stress to any portion (such as bezel flat area). Bends or twist described above and undue stress to any portion may cause display mura.
- ⑤ Do not press or rub on the sensitive product surface. When cleaning the panel surface, wipe it with a soft dry cloth.
- ⑥ Do not push or pull the interface connectors while the product is working. When handling the product, use of an original protection sheet on the product surface (polarizer) is recommended for protection of product surface. Adhesive type protection sheet may change color or characteristics of the polarizer.
- ⑦ Usually liquid crystals don't leak through the breakage of glasses because of the surface tension of thin layer and the construction of LCD panel. But, if you contact with liquid crystal by any chance, please wash it away with soap and water.

7.3.2 Environment

- ① Do not operate or store in high temperature, high humidity, dewdrop atmosphere or corrosive gases. Keep the product in packing box with antistatic pouch in room temperature to avoid dusts and sunlight, when storing the product.
- ② In order to prevent dew condensation occurred by temperature difference, the product packing box must be opened after enough time being left under the environment of an unpacking room. Evaluate the storage time sufficiently because dew condensation is affected by the environmental temperature and humidity. (Recommended leaving time: 6 hours or more with the original packing state after a customer receives the package)
- ③ Do not operate in high magnetic field. If not, circuit boards may be broken.
- ④ This product is not designed as radiation hardened.

7.3.3 Characteristics

**The following items are neither defects nor failures.**

- ① Characteristics of the LCD (such as response time, luminance, color uniformity and so on) may be changed depending on ambient temperature. If the product is stored under condition of low temperature for a long time, it may cause display mura. In this case, the product should be operated after enough time being left under condition of operating temperature.
- ② Display mura, flickering, vertical streams or tiny spots may be observed depending on display patterns.
- ③ Do not display the fixed pattern for a long time because it may cause image sticking. Use a screen saver, if the fixed pattern is displayed on the screen.
- ④ The display color may be changed depending on viewing angle because of the use of condenser sheet in the backlight.
- ⑤ Optical characteristics may be changed depending on input signal timings.

7.3.4 Others

- ① All GND, GNDB, H\_GND, VCC and VDD terminals should be used without any non-connected lines. ☆
- ② Do not disassemble a product or adjust variable resistors.
- ③ Pack the product with the original shipping package, in order to avoid any damages during transportation, when returning the product to NLT for repairing and so on.
- ④ The information of China RoHS (II ) six hazardous substances or elements in this product is as follows. ☆

China RoHS (II ) six hazardous substances or elements					
Lead (Pb)	Mercury (Hg)	Cadmium (Cd)	Hexavalent Chromium (Cr VI)	Polybrominated Biphenyls (PBB)	Polybrominated Biphenyl Ethers (PBDE)
×	○	○	○	○	○

Note1: ○: This indicates that the poisonous or harmful material in all the homogeneous materials for this part is equal or below the limitation level of GB/T26572-2011 standard regulation.

×: This indicates that the poisonous or harmful material in all the homogeneous materials for this part is above the limitation level of GB/T26572-2011 standard regulation.

8. OUTLINE DRAWINGS

8.1 FRONT VIEW

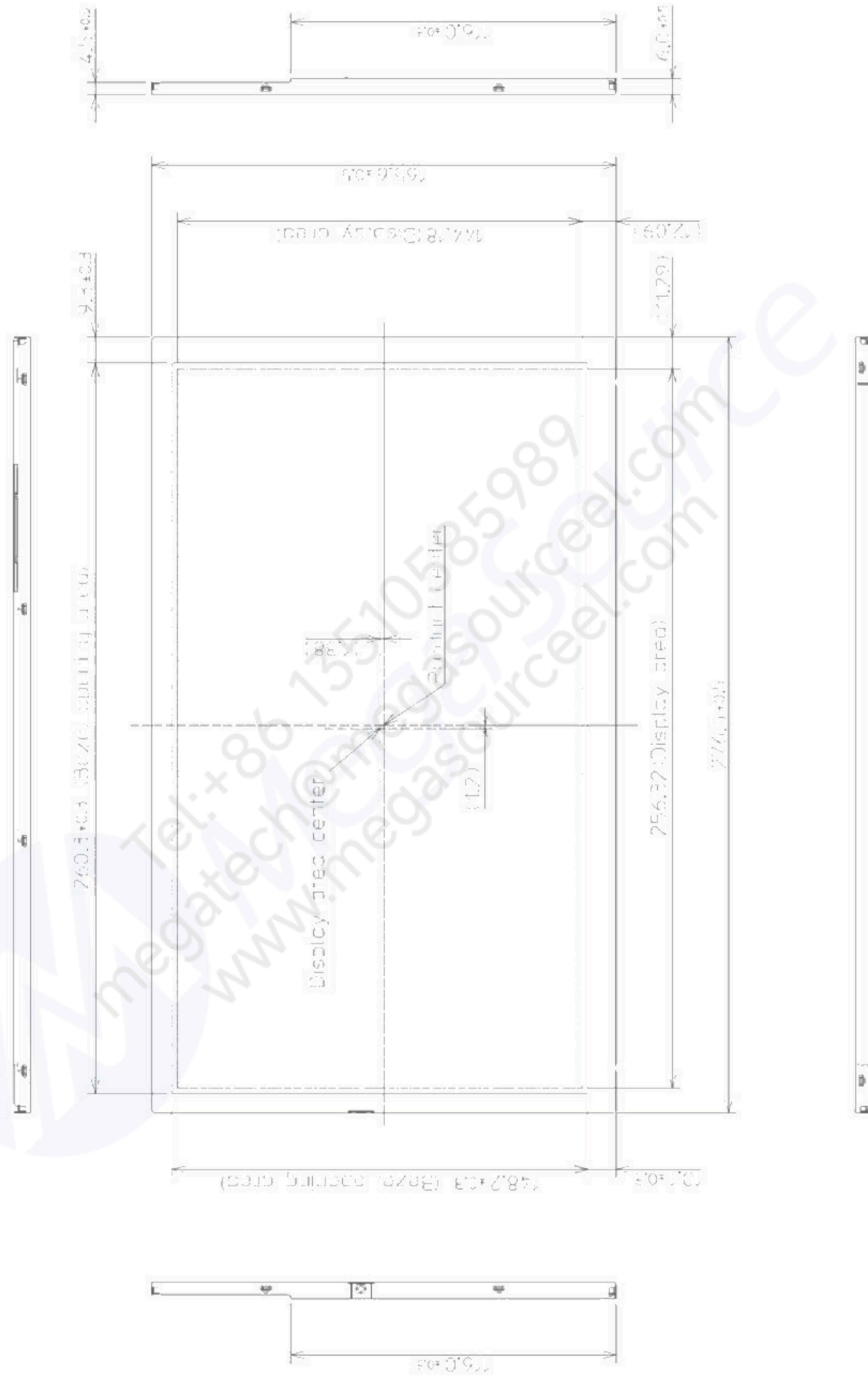

Note 1: The values in parentheses are for reference.

Unit: mm

8.2 REAR VIEW

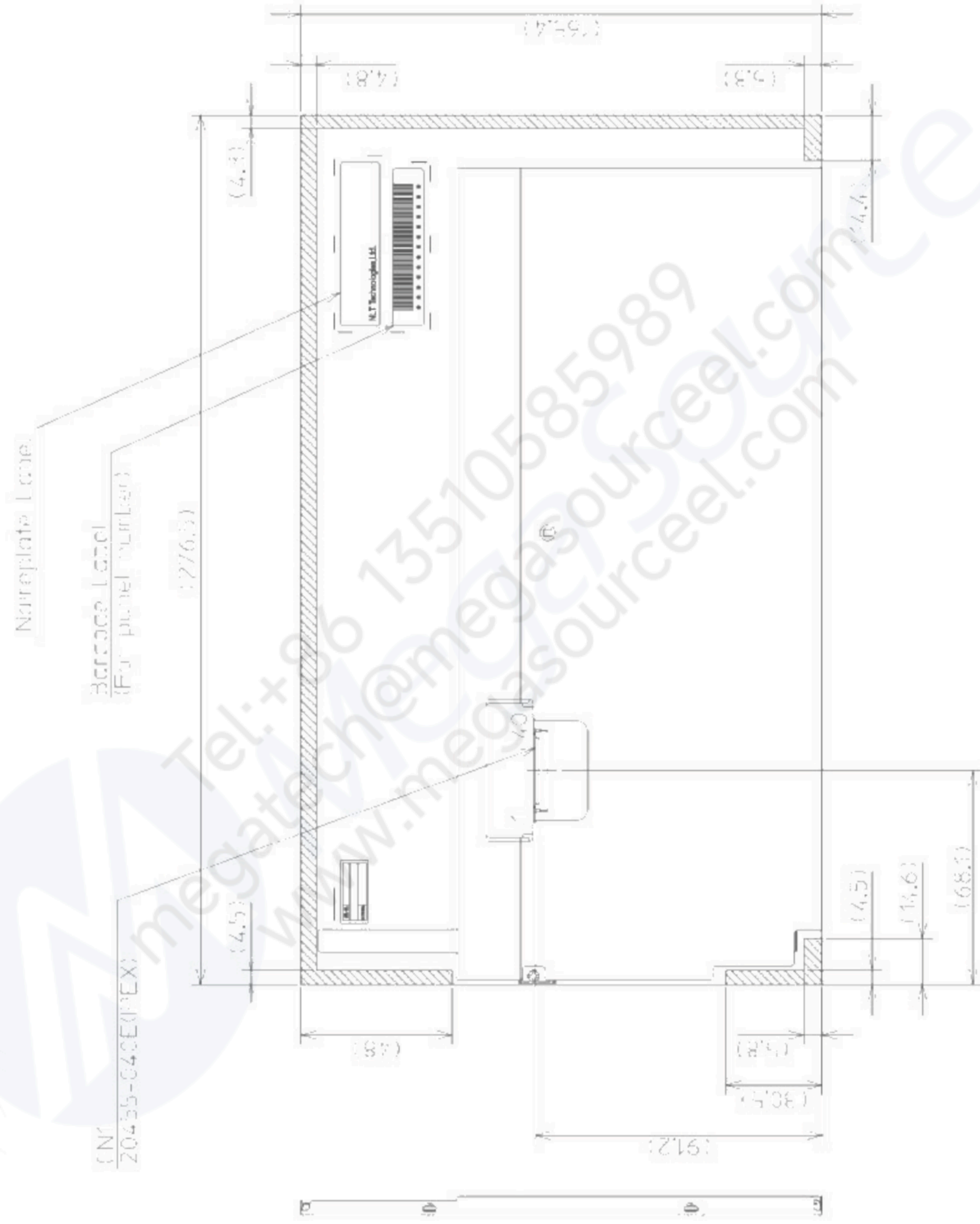

Note 1: The values in parentheses are for reference.

Note 2: The  area including edges of the front shield could be pressed.

Unit: mm